

# SIMULIA

## COMMUNITY NEWS

#11 October 2015

### THE JOURNEY FROM SOLVE TO INNOVATE

TRANSFORMATION THROUGH  
SIMULATION-POWERED INNOVATION



#### COVER STORY

ExxonMobil Looks at  
the Future of Energy



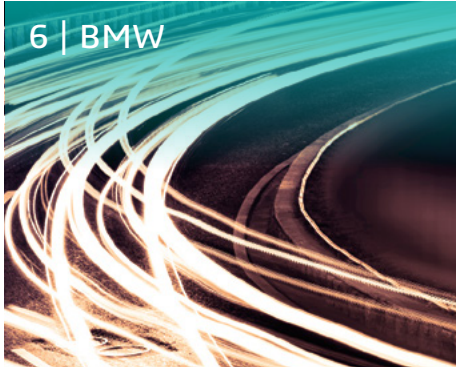

# In this Issue

October 2015

## 3 **Welcome Letter**

Dimple Shah, VP, Worldwide Sales, SIMULIA

## 4 **News**

SIMPACK: Multibody Simulation and Working with SIMULIA

## 5 **Strategy**

The Journey from Solve to Innovate

## 6 **Case Study**

BMW: Moving Toward Zero-Prototyping for Automotive Passive Safety

## 9 **Product Update**

6.14-4: New Geomechanics Functionality

## 10 **Cover Story**

ExxonMobil Looks Deep into the Future of Energy

## 15 **Academic Case Study**

West Virginia University: Plugging Design Gaps with Simulation

## 18 **Future Outlook**

Additive Manufacturing

## 20 **Alliances**

Endurica, Materialise

## 22 **Case Study**

Simulation Helps Yamaha Keep Off-Road Motorcycles Running Cool

## 25 **TADS Teachers**

Teachers at Dassault Systèmes Propelling Ahead!

## 26 **Case Study**

GN ReSound: Now Hear This!

## 29 **SIMULIA Spotlight**

Frans Peeters, Vice President, SIMULIA

## 30 **Tips and Tricks**

Modeling Tire Burst

**Contributors:** ExxonMobil Upstream Research Company, BMW Group, Eduardo Sosa (West Virginia University), Parker Group, Masakazu Yamaha (Yamaha Motor Co., Ltd.), Morten Birkmose Sondergaard (GN ReSound)

**On the Cover:** (L to R) ExxonMobil Upstream Research Company - Jorge Garzon, Senior Research Engineer; Ganesh Dasari, Technical Team Lead for Well Operability; Erika Biedegar, Well Performance Manager; Bruce Dale, Chief Subsurface Engineer; Nikolay Kostov, Research Engineer; Kevin Searles, Geomechanics Advisor and Technical Lead of new hydraulic fracture modeling technologies co-developed in Abaqus; Matias Zielonka, Senior Engineering Specialist; Jing Ning, Senior Research Engineer  
Cover Photo by Claire Jones Photography

*SIMULIA Community News* is published by Dassault Systèmes Simulia Corp., 1301 Atwood Avenue, Suite 101W, Johnston, RI 02919, Tel. +1 401 531 5000, Fax. +1 401 531 5005, [simulia.info@3ds.com](mailto:simulia.info@3ds.com), [www.3ds.com/simulia](http://www.3ds.com/simulia)  
**Editor:** Tad Clarke **Associate Editor:** Kristina Hines **Graphic Designer:** Todd Sabelli

©2015 Dassault Systèmes. All rights reserved. **3DEXPERIENCE**®, the Compass icon and the 3DS logo, CATIA, SOLIDWORKS, ENOVIA, DELMIA, SIMULIA, GEOVIA, EXALEAD, 3D VIA, 3DSWYM, BIOVIA, NETVIBES and 3DEXCITE are commercial trademarks or registered trademarks of Dassault Systèmes or its subsidiaries in the U.S. and/or other countries. All other trademarks are owned by their respective owners. Use of any Dassault Systèmes or its subsidiaries trademarks is subject to their express written approval.





## DRIVING THE POWER OF OUR COMMUNITY

We are inspired by you—the pioneers of our simulation community—as you constantly surprise us with creative use of our products and technologies to address first of its kind challenges. Many of you attended our record-breaking and exciting SIMULIA Community Conference (SCC 2015) in Berlin and experienced a vibrant simulation community at its very best. The breadth and depth of keynotes and presentations, seminars and training sessions were unprecedented as you and your fellow SIMULIA peers and partners came from all over the world to share, learn and be moved from each other's successes.

It's your active participation that makes our community stronger. In case you missed the SCC 2015 experience this year, we welcome you to participate in your local Regional Users Meetings (RUMs), sign up for training courses at our Centers of Excellence or join our Learning Community to converse with your peers online.

Across industries, we see compelling evidence of our users continuing to power innovation with SIMULIA products and technologies, as this issue of SIMULIA Community News most aptly demonstrates. Our cover story shows how our long history of collaborating with ExxonMobil has helped put them at the very forefront of innovation in the Energy industry (see page 10).

A great example of a forward-looking mindset driving transformation is BMW Group's achievement of zero prototyping for passive safety with its BMW 6 Series Gran Coupé (page 6). Leveraging the predictive power of simulation to eliminate the need for prototypes, BMW Group continues to collaborate with SIMULIA to ensure that we deliver solutions to meet the needs of new car platforms and ever-evolving stringent safety regulations.

Well, the proverbial thinking outside the box—or, in this case, inside a tunnel—engineers at the University of West Virginia came up with the idea of using a giant inflatable plug (page 15) to close an underground space in the event of an emergency. This is a great example of how sharing best practices of applications from one industry at an SCC or a RUM sparks new ideas in another. The Abaqus technologies used in this particular application were originally developed for automotive airbags!

I also invite you to read about how Yamaha tackled the challenge of protecting the radiator assembly of their renowned off-road motorbikes (page 22) and how GN ReSound took on the task of buffering their sophisticated hearing aids from inevitable human fumbles (page 26).

More inspiring stories of innovation will continue to surface as you endeavor to deliver transformation in your industries. We are excited to be with you in this journey and our commitment to you remains absolute.

We hope to see you soon at a RUM and our training events. Let us know what you want to achieve next!

**Dimple Shah**  
VP, Worldwide Sales, SIMULIA

## SIMPACK: MULTIBODY SIMULATION AND WORKING WITH SIMULIA

Roger Keene, VP, SIMULIA Worldwide Operations

Dassault Systèmes is, at its heart, a technology company. SIMULIA aims to provide state-of-the-art simulation technology that our customers can confidently use in a production environment. We advance that technology in three ways. First, we continually develop our existing products, adding new features, improving performance and making them easier to use. Second, we broaden our offerings by acquiring companies that take us into new areas of simulation. Finally, we partner with companies that have products and technology that complement what we provide.

In each case, we are always looking to provide our users with the best and latest technology. A case in point is SIMPACK, which was acquired by Dassault Systèmes in July 2014. SIMPACK provides the best, most robust, multibody simulation (MBS) technology available. It can routinely solve problems that other MBS products struggle with. It offers the capability to solve SIMPACK models in real-time, allowing, for example, an automotive engineer to adjust suspension parameters in the model and get immediate feedback on the change in ride and handling using a driving simulator.

SIMPACK models are typically much smaller than FEA models, between 50 and 2000 degrees of freedom with a frequency range of 0 to 10kHz. SIMPACK uses relative coordinates to assemble the system of equations, whereas most other MBS products (and Abaqus models using connectors) use absolute coordinates. While this makes it more complex to develop the equations, it results in far fewer equations overall and hence significantly reduced run times and greater robustness and accuracy. The matrices that SIMPACK solves are dense, unlike the sparse matrices that Abaqus generates. This means that the solvers in Abaqus and SIMPACK are very different, each highly tuned to the types of equations being solved.

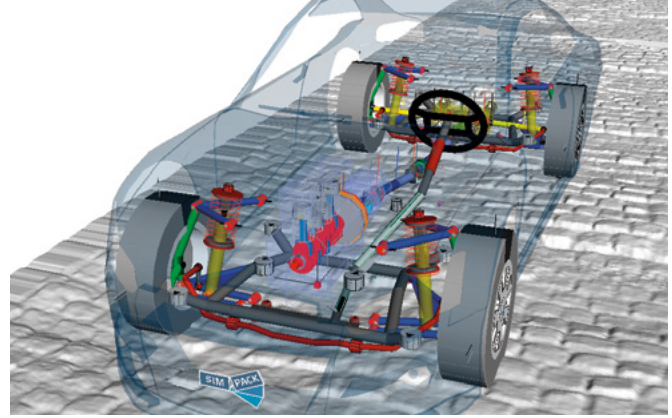

SIMPACK complements the rest of the SIMULIA portfolio. Any part in a system model can be made flexible using an Abaqus superelement so the fidelity of the model can easily be increased as the design matures. Loads determined using SIMPACK can drive an Abaqus simulation and fe-safe can calculate the durability of the components. Isight can automate and optimize SIMPACK workflows, CATIA Systems/Dymola can be used for controls, hydraulics and non-mechanical aspects of the system model, and the **3DEXPERIENCE**® platform can be used to manage all the SIMPACK data. Future releases of our products will significantly increase this interoperability. However, SIMPACK will continue to be open using flexible bodies from other FEA tools, controls from Matlab/Simulink, and tire models like F-Tire and CD-Tire, for example.

SIMPACK is particularly strong in three main industries. In the automotive industry, it is widely used to simulate vehicle ride and handling, NVH and driveline as well as engine dynamics. SIMPACK is the de-facto standard for systems simulation in the rail industry and, more recently, SIMPACK has been used extensively to model wind turbines. SIMPACK contains functionality specific to these applications such as models for bearings, gears, belt drives and tires.

The recent SCC reminded me that SIMULIA users like to push the boundaries—using our tools in novel and innovative ways. Great support by skilled technical specialists has therefore always been a key part of the SIMULIA user's experience. SIMPACK complements this with highly skilled teams in France, Germany, Japan, U.K. and U.S.A. that work closely with customers to ensure that they get the best out of the SIMPACK software.

Integration of SIMPACK into SIMULIA is well underway and will be complete in 2016. Today SIMPACK continues to be sold and supported by the existing SIMPACK organization. In the first half of 2016, the Dassault Systèmes sales teams will take over the commercial aspects of the customer relationship, allowing the SIMPACK experts to focus on support, training and services. We will also add SIMPACK expertise to our Centers of Excellence in countries where SIMPACK doesn't currently have employees.

SIMPACK is a great addition to the SIMULIA product portfolio and an important part of our multiscale–multiphysics strategy. If you aren't yet familiar with SIMPACK, I encourage you to try it soon.

**For More Information**

[www.3ds.com/products-services/simulia/products/simpack](http://www.3ds.com/products-services/simulia/products/simpack)





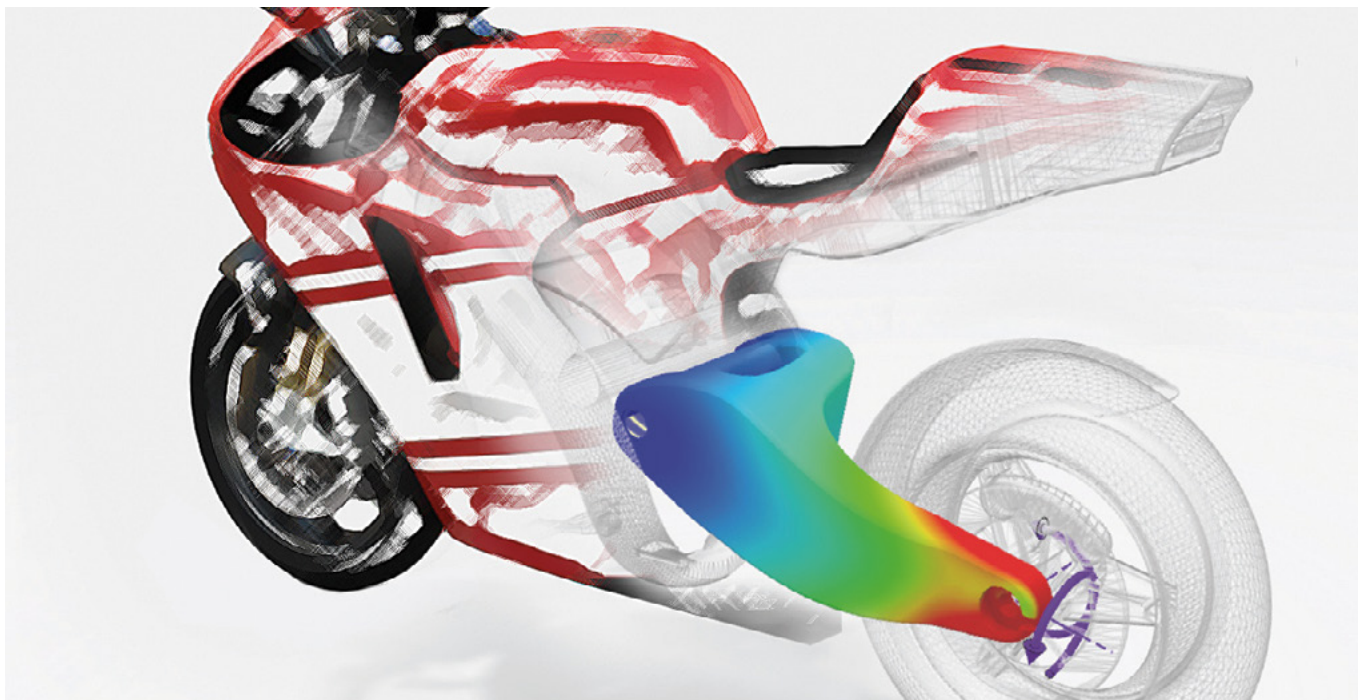

## THE JOURNEY FROM SOLVE TO INNOVATE

Our identity at SIMULIA is “Simulation for Product, Nature, and Life.” This phrase is a very broad description of what our solutions can do—from Products such as simple o-rings to entire airplanes, to Nature such as volcano magma chambers and oil reservoir geomechanics, to Life such as our Living Heart Project and Virtual Human initiative. Simulation today is a growing part of the business processes in many industries involved with Product, Nature, and Life, and SIMULIA is continuing to grow rapidly as a result.

Our value proposition is “Simulation powers Innovation!” We know it is true from the many wonderful stories of users who have transformed their company’s products using simulation to improve performance and reliability of existing products and to even discover new design concepts that would not have been found without computation. It is much more than just simulation-based design—it is simulation-powered innovation.

Three things are required to practice simulation-powered innovation. You need Technology—and lots of it—because innovation is hard work. You need a Platform—to collaborate, share, expose, and institutionalize the value of simulation throughout your entire enterprise. And most importantly, you need the Innovator—a user who goes beyond the “solve” aspect of simulation and who appreciates the power of virtual insight to change the game.

“Innovator” is a scary word. It sounds like risk-taking, like being at the cutting-edge, like being a pioneer or inventor. Nothing could be further from the truth. Simulation-based innovation reduces risk, helps you identify and stay away

from the cutting edge of failure, and leverages all of your learning to discover something new and possible—to discover something new and possible—then let’s you do it all over again. We have seen many examples already at our SIMULIA Community Conferences of Innovators at work—engineers like Dan Price from adidas, Brett Staubach of Pratt & Whitney, Dominique Moreau of Airbus, and Martin Hilchenbach of Max Planck Institute. This issue features the story of Bruce Dale at ExxonMobil, a company recognizing the value of simulation to help extract our precious natural hydrocarbon resources safely and efficiently. In addition to these role models, the tools you need to innovate are also already at your disposal. From the Power of the Portfolio suite to **3DEXPERIENCE** simulation to the value offered by our partner’s products, simulation-based innovation led by the Innovator who sees the future is already a reality in many simulation groups today.

Being an Innovator is an appropriate topic for this fall’s Regional User Meetings that many of you are attending. At these meetings, you’ll be able to meet other Innovators who can help you understand the value of pushing the boundaries at your own company and who can help you realize you are not alone in the task. The simulation world is changing, and thus the world of the simulation user is also changing. Remaining simply an analyst is becoming less and less of an option—transitioning your thinking from “solve” to “innovate” is the only real career path moving forward in our busy world.

**For More Information**  
[www.3ds.com/simulia](http://www.3ds.com/simulia)



# MOVING TOWARD ZERO-PROTOTYPING FOR AUTOMOTIVE PASSIVE SAFETY

Automobile safety standards have become a moving target for manufacturers. As current and future requirements become increasingly stringent, automakers must perpetually stay a step ahead, designing and building accordingly. As a result, the latest car models are the safest ever and highway fatality rates are at an all-time low.

While meeting—and even exceeding—safety requirements is clearly a priority for automakers, the drive to improve vehicle safety is just one of several factors creating economic pressures on OEMs these days. Customer demands for a wider variety of car models and performance characteristics, tougher mileage standards that require reduced vehicle weight, and the development of more advanced materials—all these need to be factored into vehicle design without compromising crashworthiness. Staying cost-competitive under these conditions, while continuing to attract enthusiastic customers, is an ongoing priority for carmakers.

One tool that is increasingly proving its worth—from R&D department to factory floor to crash-test hall to auto showroom—is simulation software. Early adopters have

grown their in-house design engineering expertise alongside advancements in computer modeling technology with extremely positive results.

Thought leaders across the automotive industry recognized years ago that the multiple challenges of vehicle development, underscored by the need to meet ever-updating safety standards, could only be addressed successfully with improved design simulation to help identify the most creative, robust, cost-effective route to success. An ambitious longer term goal: prove out and leverage the predictive worth of simulation to the point where prototypes could be eliminated for the passive safety design of a car model.

## THE LIMITS OF PHYSICAL PROTOTYPING

While simulation has been employed in passive safety design for many years, physical prototypes are still commonly built and tested during the course of a vehicle development program. These pre-production vehicles are expensive and time-intensive to build and crash test, due in large part to the soft prototype tooling and hand fabrication required.



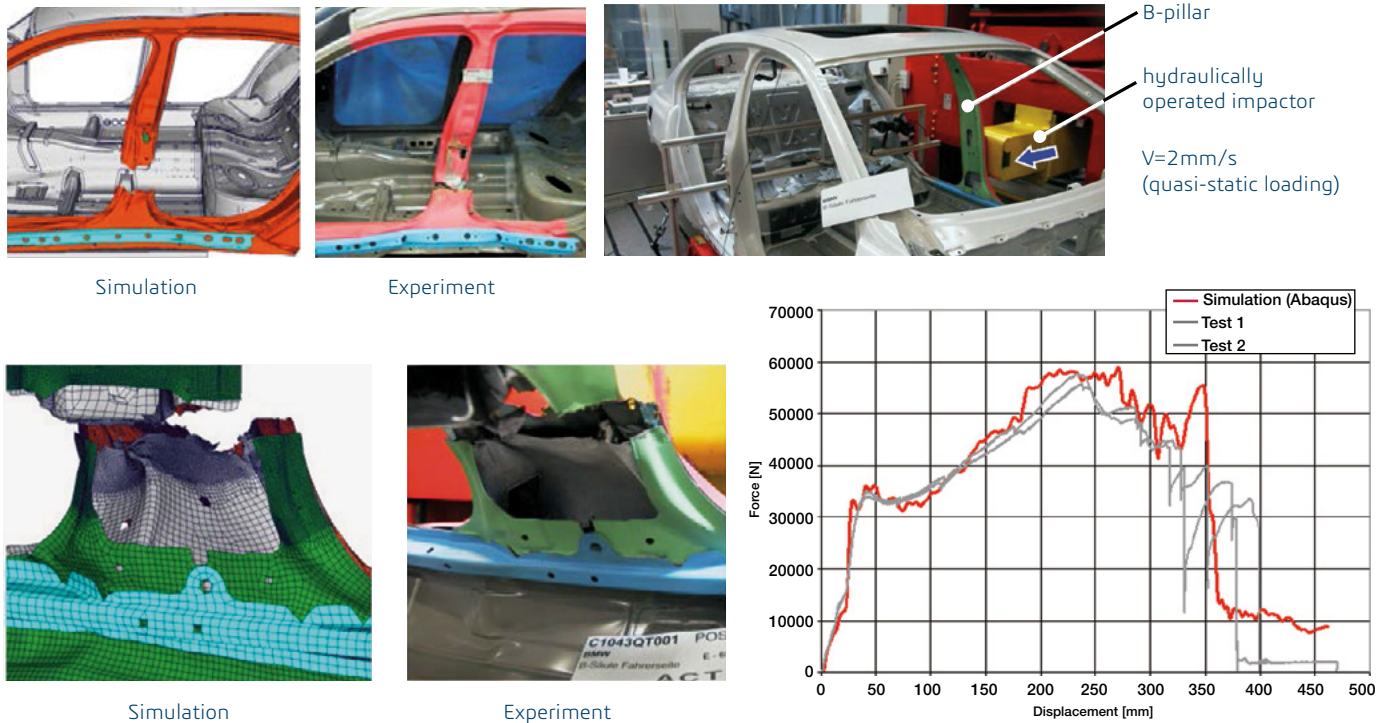

Figure 1. Abaqus simulations of material failure behavior in B-pillar intrusion experiment. The test is deliberately carried out to complete failure, and so the corresponding forces are higher than typically occur in a crash event. Predicted crack initiation and propagation correlated highly with test data, validating the material modeling approach for

deployment in production design simulation. Leveraging realistic simulation to achieve such accurate local predictions within global design models early in the vehicle program increases vehicle design development efficiency by avoiding problems later, when changes are more costly to correct and can impact vehicle launch timelines.

This type of hardware proofing has other limitations, all of which either constrain or influence results: it's impossible to test for all load cases in this way, and test results are not fully transferable to cars that roll off the production line since these prototype vehicles are hand-assembled approximations of series production vehicles.

### AN AMBITIOUS GOAL: REDUCE PROTOTYPING THROUGH SIMULATION

Premium automaker BMW Group and Dassault Systèmes SIMULIA, provider of the Abaqus FEA software suite, have partnered for more than ten years in passive safety design simulation in pursuit of this product development evolution. For computer-aided design (CAD), the automaker uses CATIA V5 (also from Dassault Systèmes).

While earlier simulations had accurately demonstrated global vehicle behavior during a collision, the team recognized that detailed local behaviors of materials and connections that could lead to damage and failure needed to be considered as well (see sidebar on page 8). For instance, it would be critical to accurately simulate the potential localized damage to the sheet metal and spot welds in the B-pillar for a side crash test, in order to accurately predict the passive safety performance of the vehicle for that load case. This level of predictiveness would be key to enabling truly virtual design iterations where important design decisions are made based on realistic simulation results.

Throughout the virtualization partnership, SIMULIA experts worked closely with BMW Group engineers to implement and test new capabilities in Abaqus, often in response to specific requirements from the automaker. New features were validated through increasingly close correlation between simulation results and real-world test data.

The BMW 6 Series Gran Coupé was then chosen as the first BMW Group car model where a zero prototype approach to vehicle development would be undertaken.

### MOVING DIRECTLY FROM DESIGN TO HARD TOOLING

A number of virtual passive safety design iterations were carried out during the BMW 6 Series Gran Coupé development utilizing the accumulated simulation results to make subsequent design modifications. The final design was predicted to meet all passive safety performance targets.

Confidence in this final design eliminated the usual soft tooling stage for prototyping, so that BMW Group could proceed directly to series production with hardened production tooling. Physical crash test results from these early series production vehicles closely matched the simulation predictions and the BMW 6 Series Gran Coupé was launched.

# Case Study

## THINK GLOBAL, BUT SIMULATE LOCAL AS WELL

Accurate prediction of crashworthiness depends on simulation of all phenomena that might affect the performance of a vehicle in a crash event. This includes global distortions of the car body and chassis, as well as 'local' failure mechanisms of materials such as sheet metal and internal joining techniques like spot welds and adhesives. Developing and deploying accurate simulation capabilities for these local failure mechanisms has been a key factor in BMW Group's zero-prototype achievement.

The graph shows the difference in simulation results for the firewall intrusion into the passenger compartment for an offset frontal crash test, comparing the earlier (green line) modeling technique and the newer (red line) modeling technique.

The virtual vehicle model without local failure mechanisms predicted an intrusion of the firewall that was 30% stiffer than the more complete model that included all important failure mechanisms. In other words, the less complete model led to the non-conservative prediction that there was less intrusion into the passenger compartment than would actually occur. The newer, more comprehensive approach is employed as standard practice in all crash simulations.

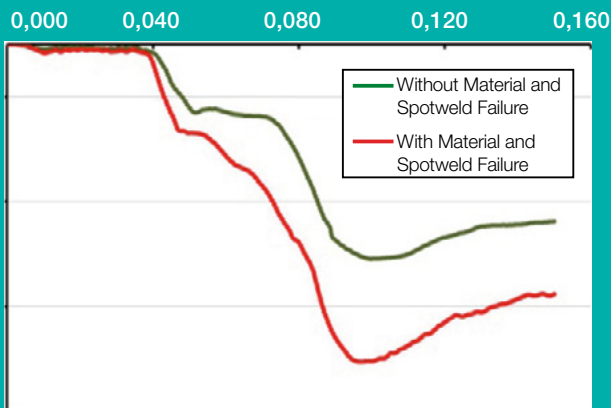
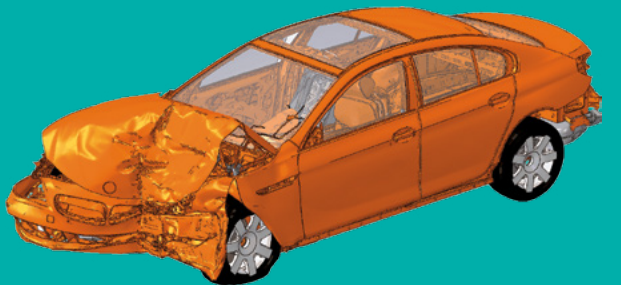

Frontal offset crash test simulation in Abaqus FEA (top) and corresponding firewall intrusion results with and without local failure mechanisms incorporated in the model (bottom).

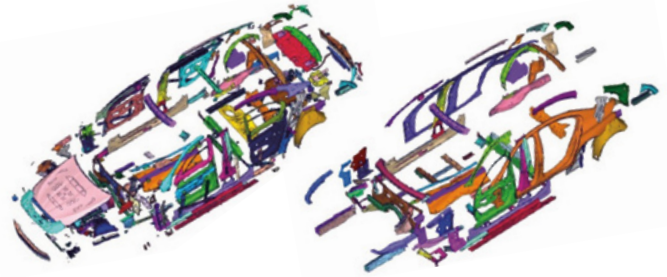

Figure 2. Modeling potential sheet metal failure during a crash test simulation is standard practice at BMW Group. The figure on the left shows the typical body components where this is considered. The effects of prior forming processes, such as stamping, can have an influence on failure, and the figure on the right shows the typical components where results from earlier forming simulations are mapped onto their crash model counterparts.



Figure 3. Side impact load cases are often the most difficult from a crashworthiness perspective. The figures above show actual BMW 6 Series Gran Coupé results for two standard side crash tests: IIHS side impact with moving deformable barrier (left); and FMVSS 214 side pole impact (right). For each, the corresponding design simulation results are also shown which accurately predicted the passive safety performance and led to the zero-prototype success.

## THE JOURNEY CONTINUES

The high level of predictiveness of the simulations gives engineers greater insight into how to improve and optimize future car designs. As vehicle platforms continue to evolve—to multi-material construction—simulation will be an instrumental tool for designers and engineers. SIMULIA will continue to collaborate closely with BMW Group to ensure that passive safety simulation capabilities in Abaqus are enhanced to accommodate fresh platforms and ever-more stringent safety requirements.

Of course real-world crash tests are always the final proof for assessing the ultimate value of simulation. While creating and following a roadmap towards zero-prototyping takes time and commitment, accurate and robust simulation capabilities can and should play a central role, enabling automakers to reach new passive safety milestones throughout the product development journey.

For More Information  
[www.BMW.com](http://www.BMW.com)



## PRODUCT UPDATE 6.14-4: NEW FUNCTIONALITY ADDED TO GEOMECHANICS APPLICATIONS

Abaqus 6.14-4 is a maintenance update to Abaqus 6.14 available now, that contains new functionality related to geomechanics applications. While many of these features have been developed through SIMULIA's ongoing collaboration with ExxonMobil, they should also be of general interest to the oil & gas design-engineering community.

- **Enhancements to the critical state (clay) plasticity model**

Previously the clay plasticity model could only be used with isotropic materials. However, since in a typical reservoir deposit the entire deposit is stratified, these new enhancements enable the model to be used to study deformation of stratified, orthotropic materials such as laminated shale. This enhanced, constitutive model now includes an anisotropic yield function and orthotropic elastic behavior. Figure 1 shows the result of a far-field boundary analysis that looks at where cracks develop around a borehole and captures behavior both near the borehole as well as the transition to a far-field crack.

- **Generating particles based on user specifications for the discrete element method (DEM)**

Abaqus' capabilities for solving both fluid and structure problems at the same time continue to advance. You can now easily generate DEM particles during the course of an analysis to set up a complex model of several different particle species. The particle generator can introduce a mixture of several particle species during a simulation via an arbitrarily shaped inlet surface, which can translate, rotate, expand, skew, or collapse during a simulation. Each particle species in the mixture can have a different particle size distribution defined by a probability density function, which allows simultaneous generation of particulate media of large and small sizes (such as a mixture of sand, cement, and aggregates) with different mass flow rates. This enhancement has obvious applications to industries where material transport simulation is needed, including Industrial Equipment (conveyor belts and other continuously moving machinery), Consumer Goods (manufacturing simulation), Transportation and Mobility (tank filling), and other industries.

- **Nonlocal averaging of the stress and strain fields to improve the accuracy of crack propagation directions**

This enhancement is all about improving the accuracy of crack prediction; to better evaluate the stress and strain fields ahead of a crack tip it is more accurate to smooth out, or average, the result some distance away. When using the Extended Finite Element Method (XFEM) to model hydraulic fracture problems in Abaqus/Standard, coarse and/or unstructured meshes of coupled pore-pressure elements can now use this kind of nonlocal averaging. This functionality was previously only available for stress displacement elements.

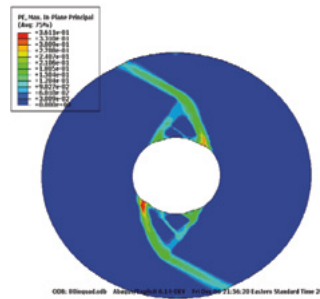

Figure 1. Constitutive model of crack generation from borehole (white space) to far field.

- **Fluid pipe and fluid pipe connector elements**

This enhancement helps predict hydraulic pressure differentials in a reservoir model, from the surface down to the reservoir and vice-versa. New fluid pipe and fluid pipe connector elements are now available to model fluid flow in pipes using the pore-pressure degree of freedom. These elements add more flexibility in modeling coupled pore pressure–displacement and coupled temperature–pore pressure–displacement analyses. Abaqus also offers a number of standard built-in loss mechanisms, and a new value behavior definition for controlling flow in a portion of a pipe network during an analysis. This enhancement will be valuable for any industrial application where multiple fluid cavities are linked together such as multi-chambered air bag or balloon inflation, inflated or fluid-filled cushions, or consumer products including fluids that can move from one chamber to another during loading.

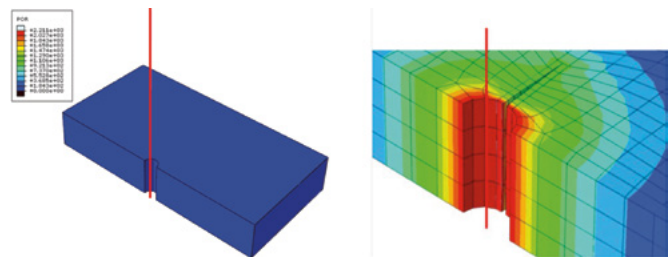

Figure 2. (Left) Global model of pipe (red) and ground and (right) close-up view of FEA analysis of crack generation at the borehole.

- **Mechanical pore pressure loads on pore pressure elements**

This enhancement helps with modeling both the fluid and the contact pressure consequences of the opening of a crack face. You can now easily apply a proper mechanical surface that was previously difficult to include, and predict the fluid-pressure loads that are also very important to the overall response of a system. For example, in the case of a borehole in an oil drilling operation, the fluid pressure acting on the wall of the borehole can create hoop stresses that are large enough to fracture the wall and allow the drilling fluid to leak off into the formation.

**For More Information**  
[www.3ds.com/simulia](http://www.3ds.com/simulia)

# ExxonMobil LOOKS DEEP INTO THE FUTURE OF ENERGY

Long-term partnership with SIMULIA contributes to evolution of advanced simulation tools for the oil & gas industry

In just the last decade, the outlook for clean-burning natural gas as a major contributor to meeting global demand for energy has dramatically changed. In 2000, shale gas represented just one percent of natural gas supplies in the U.S., for example. Today that figure is 30 percent and rising.

Why? Because innovative solutions, developed from technologies long used by oil and gas companies, are now being applied successfully to unconventional resources like shale rock as well. This subsurface work is filled with all kinds of technical challenges that require detailed insights and understanding of the complex physics involved. One major company taking a leadership role in the use of simulation to power such innovation is ExxonMobil.

ExxonMobil was an early licensee (in the late 1970s) of Abaqus software in the energy sector. The relationship was more than simply commercial—ExxonMobil was also an early collaborator with SIMULIA on technology development to enable simulation of key energy-sector performance challenges. For example, collaboration with ExxonMobil led to the very first large sliding displacement capability in Abaqus. This technology was used to increase pressure and temperature capacity as well as reliability of threaded-pipe production tubulars and equipment.



Bruce Dale, Chief Subsurface Engineer for ExxonMobil, first described his company's three-plus decades' collaboration with SIMULIA and its predecessors during a keynote speech at the 2010 SIMULIA Community Conference. Shortly after that speech, his engineering team

embarked on a new effort with SIMULIA to further strengthen simulation capabilities that would help address the many challenges involved in subsurface extraction of shale gas. This collaboration would concentrate on the development of state-of-the-art general purpose material models, finite element technology, and computational procedures aimed at identifying working solutions to such challenges.

The team consisted of senior engineers at ExxonMobil partnering directly with SIMULIA personnel. In particular,



Kevin Searles played a significant role in establishing the key technical underpinnings and advising the joint development collaborative steering team since its inception. Also important has been the sustained ExxonMobil management leadership of Bill Kline, Jason Burdette and Erika Biediger over the duration of the joint project. (See sidebars for profiles of contributors.)

At this year's SCC in Berlin, Dale returned to provide a fascinating in-depth look at just how far the joint partnership with SIMULIA has progressed and how sophisticated the resulting capabilities have become over the last five years. In addition to the SCC, the ExxonMobil team is rolling these technologies out at oil and gas technical events as well.

"This collaborative effort between ExxonMobil and SIMULIA has led to the development of fundamental improvements in simulation to address key drilling, completion and production challenges in the oil and gas industry," said Dale. "Advanced simulation technologies and 3D visualization play an increasingly vital role in the success of the energy industry and include such modeling capabilities as finite element analysis (FEA), computational fluid dynamics (CFD) and particle flow dynamics (PFD)."

Dale has been a participant in this effort since the start of his career with Exxon in the 1980s, beginning with research and development supporting the drilling business and moving into management and leadership roles over time. He is a champion of new "game changing" technologies; and fostered innovation, creativity and excellence throughout his 34-year professional career. "I had an opportunity early on to work with Abaqus, part of the Dassault Systèmes SIMULIA suite of tools, and that was a great way to apply advanced technology to simulate those things which, in the past, we'd only been able to test in the laboratory or in the field," he said, in an interview after his 2015 talk.

"I've always had a natural curiosity, wanting to figure out the 'why' of things—and one thing that led to was the early use of technology from its infancy." [Other things his curiosity





has led to include 20 patents issued for his ideas, and 40 or so more in progress!] As the simulation capabilities in Abaqus have expanded, Dale said, "I've been fortunate to work with a number of very talented and bright people. When we collaborate using these tools, the ideas just begin to flow."

Employing simulation at ExxonMobil has increased the company's competitiveness, Dale said. "The power of being able to connect the dots is one you're never able to do fully in the laboratory because of cost, size and time," he said. "In the past, the time available often wouldn't fit within the period where decisions had to be made.

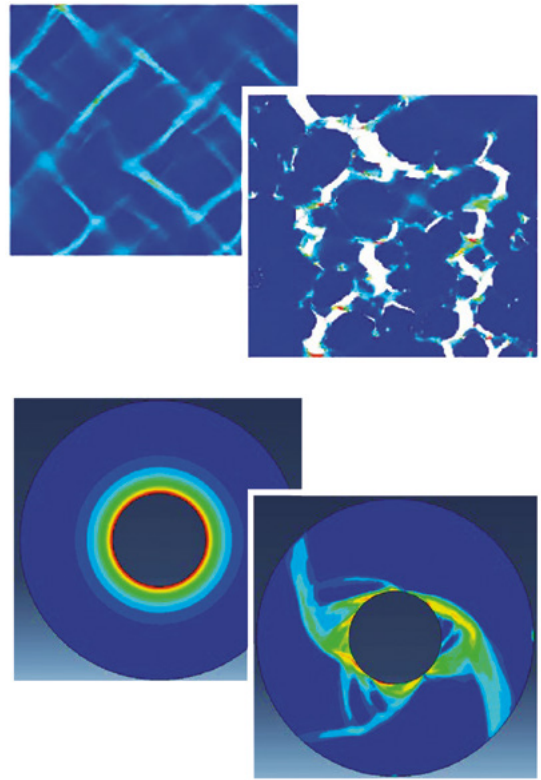

(Top) Advanced finite element models and (Bottom) advanced constitutive models, co-developed between ExxonMobil and SIMULIA.

## SCOPE OF THE COLLABORATIVE INITIATIVE

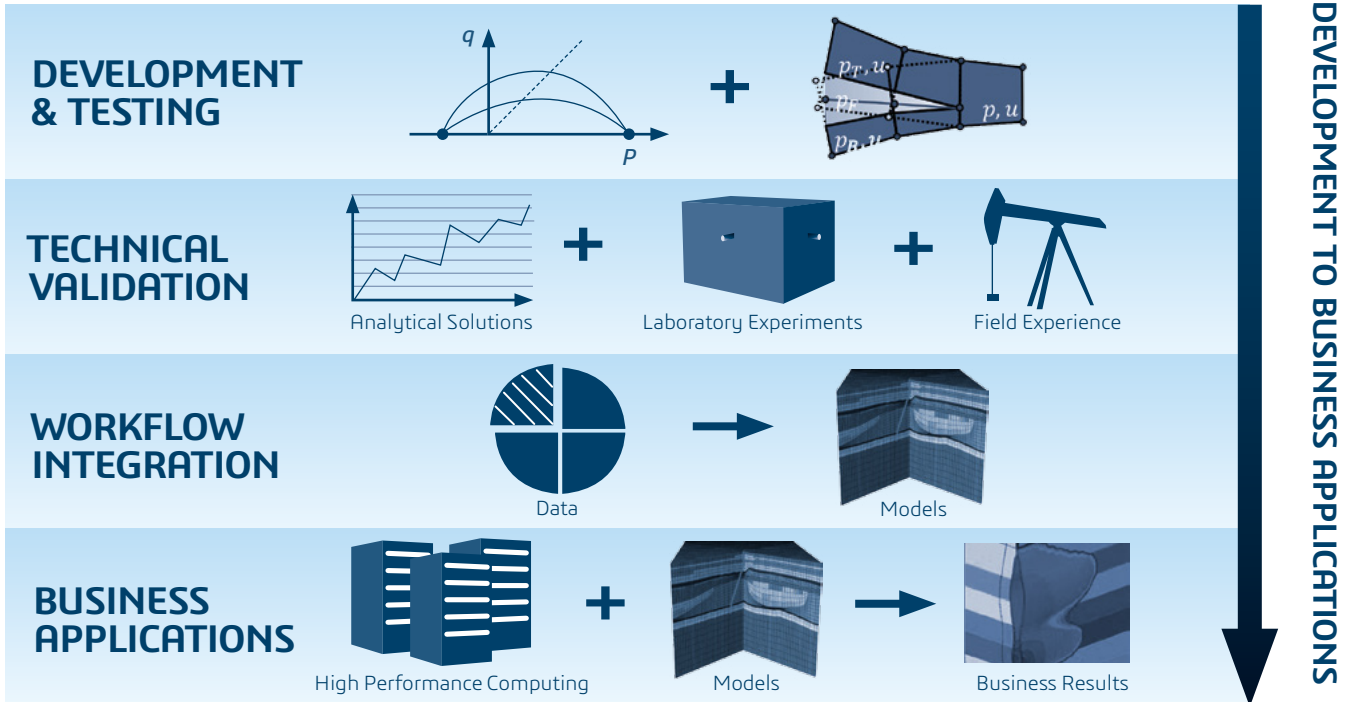

# Cover Story

## JING NING



Jing Ning, a senior research engineer, finished her Ph.D. in mechanical engineering at Cornell University and joined ExxonMobil Upstream Research Company in 2013. She is currently working on drill cuttings, re-injection, and hydraulic fracture modeling of various aspects of water injection. "It has been a great experience working with SIMULIA engineers on this joint development agreement," she says. Pablo Sanz, co-author of the SCC 2015 paper, explains how "Simulation has made our work more productive in that more accurate results can be delivered to the business for a small increase in time." In their SCC 2015 paper, [Experimental Validation of Simulation Capabilities for Hydraulic Fractures Propagating in a Porous Medium](#), Ning, Sanz and teammates found good agreement between Abaqus simulation and experimental results for two benchmark studies of fluid-driven fractures. "Solving these challenges is critical to the business values we are going after," says Sanz.

## JORGE GARZON AND MATIAS ZIELONKA



Jorge Garzon, a senior research engineer in the well performance section of the ExxonMobil Upstream Research Company, has a Ph.D. in civil engineering from the University of Illinois. He works on the creation of 3D geomechanical models for analyzing phenomena such as slippage between faults and wellbore and casing integrity. "These recently developed capabilities combine the sophisticated physics of "research codes" with the ability to run "fast enough" models for full-scale commercial applications," he says. "This helps us predict the geometry of hydraulic fractures and the pore pressure changes resulting from oil and gas operations." Jorge and Matias Zielonka wrote [Advanced Fracture Modeling for Cuttings Re-injection](#) for the 2015 SCC. Matias is a senior engineering specialist in the surveillance and well simulation function at the Company. He holds a Ph.D. degree in aeronautical engineering and applied computation from Caltech. "These fully coupled capabilities we've developed with SIMULIA allow us to test scenarios that cannot be reproduced in the lab and to apply what we learn to our models with great accuracy," says Matias.

"The visualization now possible with simulation allows you to do the interpretation—to spot either opportunities or flaws—a lot earlier. This impacts and affects the here and now much more so than ever before. So in the upstream business, visualization is a great aid, able to bring folks together with disparate types of information analyses and data to solve some very tough challenges."

In his 2015 SCC address, Dale discussed his company's commitment to developing natural gas resources in a safe and reliable manner. ExxonMobil has developed best management practices to increase efficiencies while reducing the overall environmental footprint, he said. This includes protecting local ground water resources, working closely with communities and government and promoting transparency and efficient regulation.

Dale explained that extracting natural gas from shale rock involves the complex physics of

- Drilling (creating a useable borehole)
- Completion (providing a conduit from the reservoir to the surface)
- Stimulation (enhancing the connectivity of the well to the reservoir rock face)

ExxonMobil test facilities.





## NIKOLAY M. KOSTOV



Research engineer **Nikolay M. Kostov** joined ExxonMobil's Upstream Research Company after finishing his Ph.D. in mechanical engineering at Rice University. He is now using Abaqus for modeling drilling-induced fractures and wellbore integrity prediction. The paper he and colleagues submitted for the 2015 SCC, [Dynamic Hydraulic Fracture Modeling for Wellbore Integrity Prediction in a Porous Medium](#), describes the unique fracture-modeling capabilities in Abaqus that use advanced CZM (Cohesive Zone Method) elements. "The automated workflow allows a much better use of my time," he says. The tools he and his team have developed together with SIMULIA have increased their confidence in predicting scenarios, he notes: "Some properties that aren't well known in advance can nevertheless be estimated with empirical models. We can also specify ranges of values instead of individual ones to cover areas of uncertainty."

## GANESH DASARI



**Ganesh Dasari** is the technical team lead for well operability and subsurface geomechanics in ExxonMobil's Upstream Research Company. Ganesh joined the Company in 2003 after finishing his Ph.D. in civil engineering at Cambridge University. Describing his group's work in their 2015 SCC paper, [Simulation of Hydraulic Fracturing of Unconsolidated Sands using Fully Coupled Poro-Elastoplastic Models](#), Dasari says, "Fracturing in unconsolidated sands involves complex failure mechanisms. Our realistic material model is the key to capturing this behavior and optimizing fracturing design."

These advanced Abaqus models showed that fracturing in sands was dominated by shear failure as opposed to the type of tensile failure seen in hard rock. "We were pleased that our model captured this key feature," he said. "These encouraging results allow us to apply simulation to field scale injection problems at increased length and time."



- Production (managing the flow of reservoir fluids through the well, treating facilities and piping systems)
- and Waste Disposal (re-injection of untreatable fluids safely back into deep subsurface horizons)

In order to accurately model the critical factors that can impact the success of these many phases of extraction, ExxonMobil and SIMULIA have now developed a fully coupled formulation for fluid-driven (hydraulic) fracture growth using two advanced finite element methods: a cohesive zone method (CZM) in which fracture trajectory is confined to a plane; and an extended finite element method (XFEM) in which fracture trajectory is entirely solution dependent.

In addition to these advanced finite element methods, advanced constitutive models were also implemented in Abaqus to account for the inelastic deformation associated with the types of unique, complex failure mechanisms seen in soft rock.

In all cases, methodologies have been rigorously validated over a wide range of rock and fluid properties as well as fluid-loss conditions, both against semi-analytical solutions and against lab-scale experimental results.

ExxonMobil has developed unique experimental capabilities in-house, then worked with SIMULIA to create 2D and 3D

# Cover Story

## ADDITIONAL CONTRIBUTORS

**Bill Kline** is Manager of the Drilling and Subsurface Function of ExxonMobil Upstream Research Company. He holds a PhD in Chemical Engineering from the University of Michigan. Bill is a co-founder of Pumps & Pipes, an international symposium series that brings together oil & gas, medical aerospace, and other professionals to explore common interests and opportunities for collaboration.

**Kevin H. Searles**, Ph.D., is Geomechanics Advisor for ExxonMobil Upstream Research Company in Houston, Texas, and Technical Lead of new hydraulic fracture modeling technologies co-developed in Abaqus. Kevin has spent the past 15 years working on reservoir compaction, thermal EOR, geothermal heat recovery, hydraulic fracturing, and cuttings/water disposal applications worldwide, including simulation. He has numerous patents on methods and processes for multi-scale geomechanics analysis, fluid injection control, and integration of geomechanics and seismic monitoring.

**Erika A.O. Biediger** is Well Performance Manager for ExxonMobil Upstream Research Company in Houston, Texas. Erika received a Ph.D. degree in Mechanical Engineering from Georgia Institute of Technology and has six U.S. patents. Erika currently manages the R&D technical team focusing on the new Abaqus fracture modeling technologies developed in conjunction with SIMULIA.

**Jason A. Burdette** is U.S. Drill Team Engineering Manager for ExxonMobil Development Company in Houston, Texas. Jason joined ExxonMobil in 2001 after receiving an MS degree in Engineering Mechanics from Virginia Tech. Prior to his current assignment, Jason managed the R&D technical team working on new Abaqus fracture modeling technologies developed in conjunction with SIMULIA.

**Pablo F. Sanz** is Well Injectability and Induced Seismicity Team Lead at ExxonMobil Upstream Research Company. Pablo joined ExxonMobil in 2008 after finishing PhD in Computational Geomechanics from Stanford University. His research interests lie in the area of computational geomechanics and fracturing with applications to drilling, subsurface engineering, and induced seismicity problems.

Additional contributors at ExxonMobil Upstream Research Company in Houston, Texas:

**Scott R. Buechler** is Well Production and Well Stimulation Team Lead.

**Michael S. Chelf** is the Well Construction Section Manager.

**Ranojoy D. Duffadar** is an Engineering Specialist in the Drilling and Subsurface function.

**Gilbert C. Kao** is an Engineering Associate.

**Sandeep Kumar** is a research engineer in the Well Performance section.

**Fuping Zhou** is Senior Engineering Specialist.



models of many different aspects of controlled hydraulic fracturing in rocks. “By incorporating physically measured input parameters and representing the full physics, not simply ‘tuning’ the models to achieve the desired results, we are confident in our validations of these newly co-developed numerical capabilities in Abaqus,” Dale said.

These recently developed simulation capabilities are supporting ExxonMobil’s hydraulic fracturing business in many ways, Dale pointed out. “Avoiding drilling problems cuts costs,” he said. “Managing drilling risk means not letting small problems become big ones. Advanced 3D simulations enhance our ability to anticipate drilling-related issues—such as instability in shales or lost returns in sands—and mitigate risks. Simulation also helps us develop innovative recovery schemes to make production more economical.”

“The fruits of our collaborative partnership with SIMULIA are many,” Dale concluded. “In the decades ahead, the world will need to expand energy supplies in a way that is safe, secure, affordable and environmentally responsible. 3D simulation powers innovative solutions by building on the fundamentals to deliver energy in the 21st century.”

**For More Information**  
[www.corporate.exxonmobil.com](http://www.corporate.exxonmobil.com)



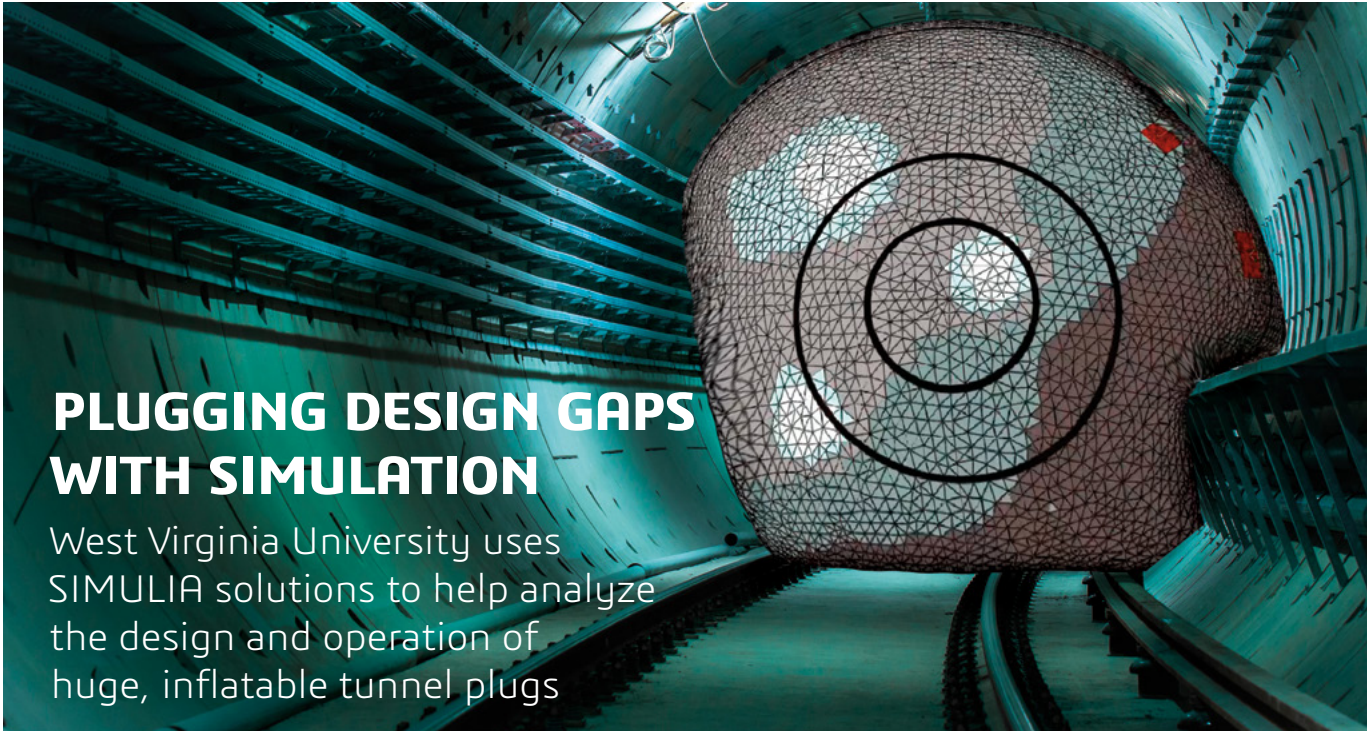

## PLUGGING DESIGN GAPS WITH SIMULATION

West Virginia University uses SIMULIA solutions to help analyze the design and operation of huge, inflatable tunnel plugs

Imagine an airbag inflating in a vehicle. Now imagine it big—really big—big enough to close off a tunnel. Such a structure, expanded in an underground mine, subway, or road tunnel, would surely stop traffic. It would also stop the advance of water, excessively heated air, or toxic, chemical, and biological agents in the case of a flood, fire, crash, or other emergency.

The need for such a plug exists. Consider these incidents: In the fall of 2012, Hurricane Sandy flooded seven of New York City's subways and several of its major road tunnels, closing them for days. In 1999, a truck carrying margarine and flour in the Mont Blanc Tunnel between Italy and France caught fire, filling the tunnel with noxious smoke and burning for 50 hours. In March 1995, sarin gas was released in the Tokyo subway system.

Events such as these have concerned safety officials worldwide for decades and they have considered a number of ways of closing off subways, tunnels, or pipelines in order to control hazardous conditions quickly.

### THE IMPETUS FOR INFLATABLES

In 2007, the U.S. Department of Homeland Security began looking for "out-of-the-box" ideas for protecting subway systems from extreme events, whether natural or man-made. One idea was to retrofit tunnels with rigid, metal floodgates or other types of solid structures. Another idea, which had surfaced earlier in Europe during the development of the Chunnel between England and France, was to install an inflatable plug at strategic locations inside the structure.

This inflatable concept, though never implemented in the Chunnel, was intriguing for several reasons. A plug that could

inflate quickly like a giant airbag only in an emergency would not interfere with normal tunnel operations. An inflatable would be better than floodgates at fitting to the shape of a tunnel, and especially to the obstructions within, such as tracks, pipes, and walkways. This kind of "softer" fit—i.e., conformance—could be very effective at creating an air- or water-tight seal. An inflatable would also be less bulky than floodgates, and therefore easier and less expensive to install.

The idea was to set up inflatable structures, either permanently or temporarily, in multiple locations where an emergency was anticipated. The inflatables would be folded and packed in a container, readied for activation similar to that car airbag. The plug could be inflated by air from fans installed nearby or through pipes. Sensors embedded in the tunnel walls could trigger inflation, or inflation could be activated remotely. When the inflatable was no longer needed, it could be deflated and removed. A replacement could be swapped in or installed nearby in preparation for the next emergency.

**"We've concluded that our simulations demonstrate significant benefits from the use of FEA to predict the behavior of large-scale confined inflatables, as well as estimate quantities that can't be directly obtained from physical experiments"**

—Eduardo M. Sosa, Research Professor,  
West Virginia University

# Academic Case Study

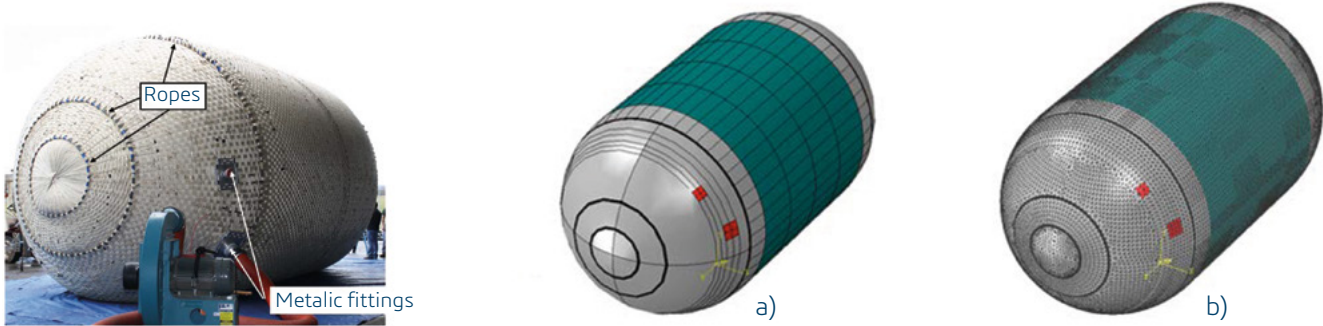

Figure 1. Inflatable plug prototype (left), and Abaqus model of the initial geometry: a) geometry b) meshed.

## HOW TO VIRTUALLY PLUG UP A TUNNEL

Intrigued by the inflatable concept, Homeland Security reached out to the mechanical and civil engineering departments at West Virginia University (WVU). A full-scale test facility was constructed and an initial concept was tried out inside a structure that mimicked a segment of an actual rail-transportation tunnel.

Of course, scaling up an airbag to tunnel size required entirely new approaches in storage, deployment, and manufacture. And real-world testing proved to be complex, time-consuming and not as predictive as desired.

So WVU turned to realistic simulation, developing a series of finite element models of a confined inflatable plug in a tunnel. "By comparing the behavior of our computer models to experimental data from the full-scale tests, we could better refine our deployment designs and improve the ability to predict the complete sequence of real-world deployment more accurately," said Research Professor Eduardo M. Sosa. He presented his results, from his work at the University with colleagues Choo-Siang Wong and Ever J. Barbero, at the 2015 SIMULIA Community Conference in Berlin.

The primary analysis tool WVU used was Abaqus Unified Finite Element Analysis (FEA) from Dassault Systèmes' SIMULIA. FEA simulations included folding, positioning, settling (from gravity), deploying, and inflating the plug, as well as the plug's conformance to a tunnel and its adjustment against other objects typically found within a tunnel.

The team's Abaqus models covered a variety of components, the main ones being the inflatable plug and a tunnel segment. The inflatable plug consisted of a cylinder with two hemispherical end-caps (Figure 1), and two metal fittings

on the same end-cap to inflate and deflate the plug. The perimeter of the plug is larger than the tunnel's perimeter for two reasons. First, the over-sizing compensates for any wrinkles and sags in the fully inflated plug after deployment. Second, it ensures better conformance, resulting in a better seal in the tunnel.

Model setup of the tunnel section was fairly straightforward. Unlike the plug, the tunnel is considered a non-deformable object, so while the structural membrane of the plug was modeled using membrane elements, the tunnel and plug fittings could be modeled using rigid elements.

## THE COMPLEXITIES OF FOLDING AND INSTALLATION

Simulations of folding and positioning the plug consisted of both rigid body rotations and translations applied as boundary conditions to selected nodes and elements on the surface of the plug model. Folding was mostly a set of geometric transformations divided into three general steps: unconstrained, unstressed inflation; flattening and grounding (Figure 2); and folding by rolling.

The second step, flattening, incorporated both horizontal displacements and vertical gravity force. The final step of rolling the flattened inflatable was simulated using rotational rigid plates to represent the successive lifting and partial rotations of simulated folds. This last step consisted of three sets of lifting and rotation, all under the influence of gravity.

Modeling the positioning of the folded inflatable also fed into the simulations for plug deployment and inflation by accounting for the effects of gravity on the deflated, folded plug (i.e., how the plug settles when stored). The settling sequence essentially restored elements distorted through

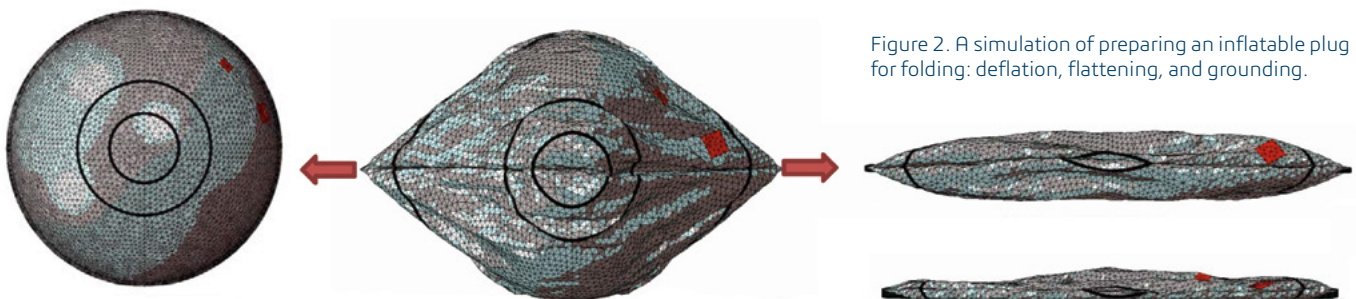

Figure 2. A simulation of preparing an inflatable plug for folding: deflation, flattening, and grounding.



## Experimental



## Deployment #4

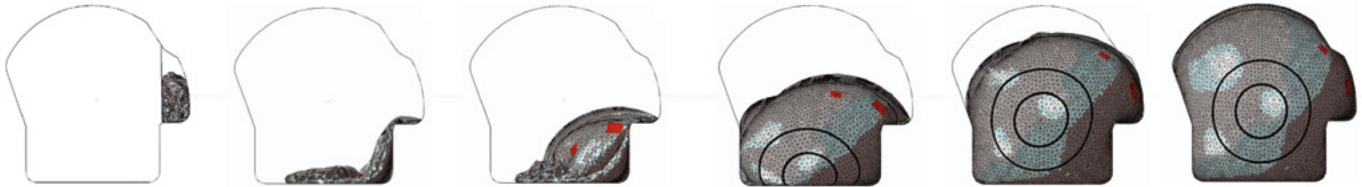

Figure 3. The simulated deployment of the inflatable plug closely matches the deployment of a plug in a full-scale test.

the folding and positioning back to their initial state before rerunning a deployment simulation. This reset also avoided distortions on the membrane surface and minimized the kinetic energy in deployment, thereby helping stabilize the entire deployment simulation.

### DEPLOYING THE PLUG MODEL

The WVU engineers based their simulations on the Uniform Pressure Method (UPM) because it is simple, computationally efficient, and adequate for modeling relatively slow inflation. The UPM implemented in Abaqus/Explicit defines surface-based cavities to model the fluid-structure interaction during deployment and inflation. These surface-based cavities were complemented by the addition to the model of multiple internal chambers for a more precise control of the airflow during the inflation sequence.

Modeling the entire deployment of the inflatable plug (Figure 3) starts with the folded plug stored against the tunnel. When the virtual vertical gate to the plug container drops away, gravity causes the plug to fall out and unroll.

For refining the accuracy of their simulations, WVU had four deployment options to explore. In the first option, the folded plug did not have passive restraints in the form of tie-downs to control the unfolding membrane, and airflow was not directed within the plug. Instead, air filled the plug evenly, spontaneously, and immediately once it entered the plug. The second option included the tie-downs. In the third option, additional stiffness was added to the tie-downs as compensation for the dynamic response associated to a mass scaling factor. The fourth option was similar to the third except that, unlike in the other options, the sequence of airflow within the plug was defined (i.e., directed).

The team's analyses showed that the first and fourth deployments were extreme cases compared to experimental results in terms of conformance. The airflow as defined in the fourth deployment caused the simulation to most closely replicate the actual behavior seen in the full-scale tests.

### THE PRESSURE TO CONFORM

Conformance is key in inflatable structures that need to tightly fill uneven spaces. Lack of conformity shows up as gaps between the inflated plug and the tunnel perimeter, usually at corners and around obstructions such as pipes. "Obviously, such gaps, and the leaks that result, need to be minimized, and this is where simulation came to be particularly useful for fine-tuning our deployment designs," said Sosa.

The position and extension of wrinkles in the plug fabric turned out to be critical too. Accumulation of membrane material in the form of wrinkles in one location leads to gaps in other locations around the contact perimeter. The presence of gaps is a clear signal of suboptimal deployment. Both wrinkles and gaps can be greatly reduced by optimizing several aspects of plug behavior including the folding pattern and deployment sequence, the location and number of passive restraints, as well as the friction characteristics of the interacting surfaces.

While previously obtained real-world data contributed to the accuracy of the team's models, conformance during full-scale inflatable tests had not been easy to measure in the test facility. But FEA could of course simulate expected conformance. Here, the ability of Abaqus to calculate contact between two objects highly accurately was of particular value: WVU found that their simulations were an extremely close visual match to real-world deployments conducted to study the contact area between the inflated plug and the tunnel walls in a variety of scenarios.

"We've concluded that our simulations demonstrate significant benefits from the use of FEA to predict the behavior of large-scale confined inflatables, as well as estimate quantities that can't be directly obtained from physical experiments," said Sosa. Going forward, the researchers plan to continue using such tools to further study other aspects of the tunnel-plug solution, including looking for additional applications that would benefit from the methodologies they have developed.

**For More Information**  
[www.statler.wvu.edu](http://www.statler.wvu.edu)

# Future Outlook

## HOW SIMULATION CAN HELP ADVANCE ADDITIVE MANUFACTURING TECHNOLOGY

James Fort, Subham Sett, SIMULIA Industry Diversification Team

Additive manufacturing (AM), also popularly known as 3D printing, is a manufacturing technology that has been evolving since the late 1980s—but can finally be said to be proving its worth in many fields. It is a layer-by-layer process by which material, metal, plastic, alloy, or a combination is fused or bonded to produce the desired part.

Recently, the technique has been more widely popularized as advancements in the technology have brought 3D printing to the desktop and the home through the Maker movement. Significantly, the scope of AM is now expanding beyond rapid prototyping into industrial applications of both tool-product and direct-part production.

Hardly a day goes by when you don't see an article in the news about a novel use of the technology, whether it is to print a prosthetic arm, design your favorite chocolate toppings, manufacture a bridge on-site, or print an entire car itself. However, significant challenges still exist in the reliability and predictability of a number of AM processes that act as barriers to part certification and a much more widespread adoption in industry.

So, the main question to ask ourselves in our community is, "How can simulation help get reliability back into AM designs? Can we design parts so they print right the first time?" Let us explore.

There are a number of key areas where simulation can play an important role in 3D printing: generating a functional design, generating lattice structures, calibrating the material, optimizing the manufacturing process, and in-service performance.

AM is unique in offering designers freedom from traditional manufacturing constraints, allowing them to take their designs to new heights to meet engineering requirements without sacrificing part strength or performance. Lightweighting is an example of this: parts can be created with a minimum of

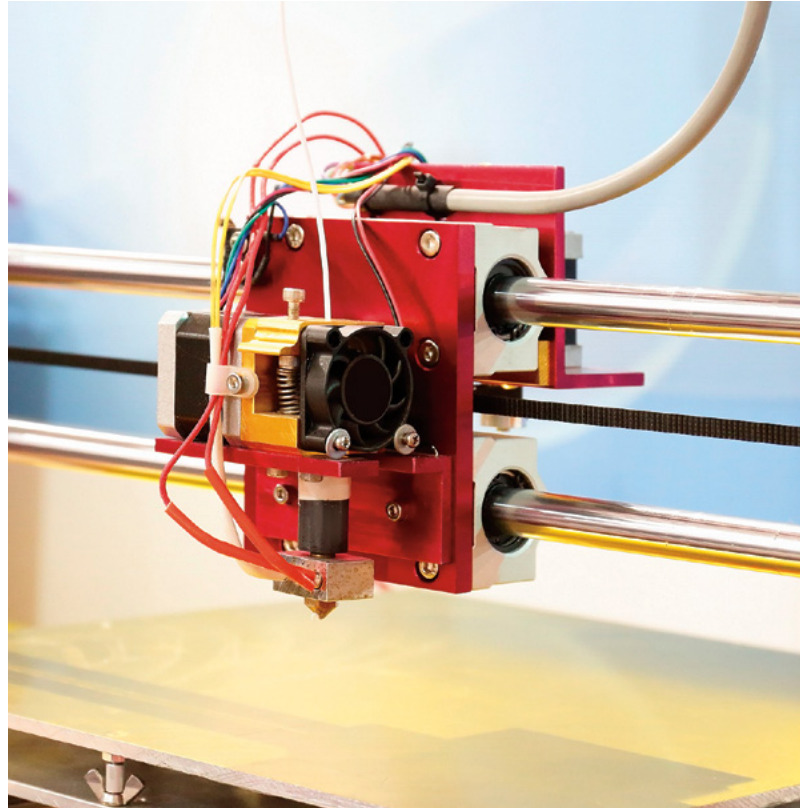

material necessary to meet specified functional requirements. Creating these kinds of designs is now feasible thanks to the proven technology of robust, nonlinear topology optimization that SIMULIA offers through the Tosca suite of products.

AM also provides the ability to create parts with extremely sophisticated internal lattice structures that would not be possible through traditional manufacturing techniques. Such lattices allow for additional weight reduction beyond that provided solely through topology optimization. Additional



Initial Design Space

Topology Optimization

Final Design



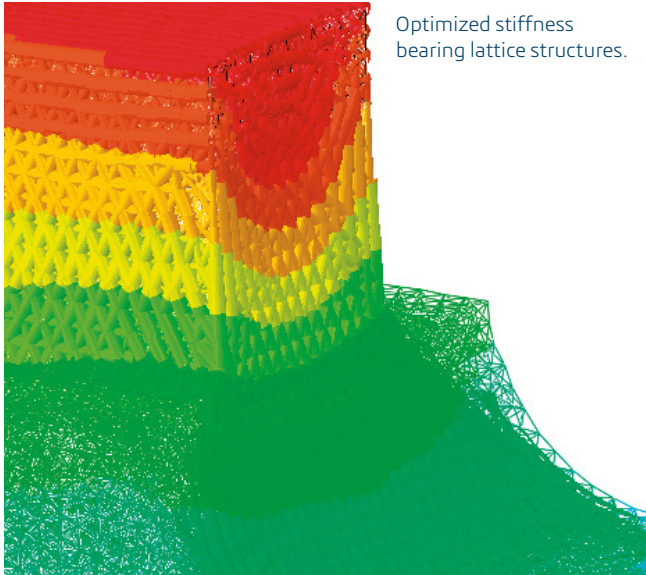

Optimized stiffness bearing lattice structures.

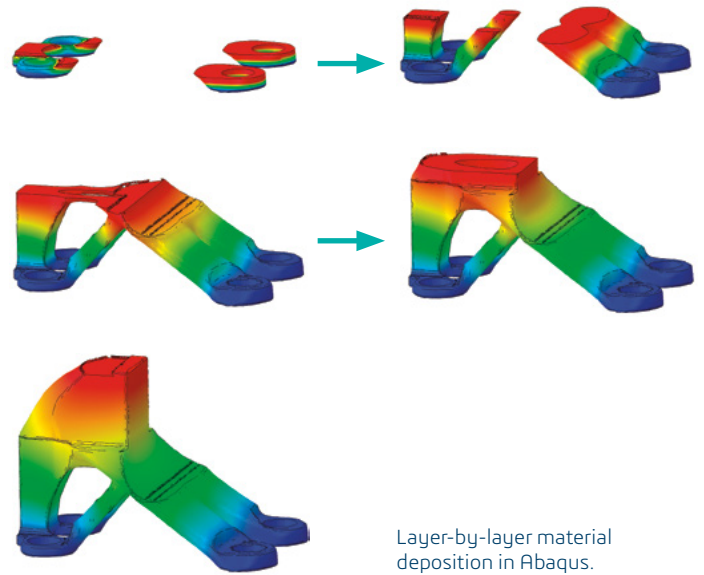

Layer-by-layer material deposition in Abaqus.

SIMULIA capabilities, to be released later this fall through Tosca, will enable users to introduce lattices into their structures as well as size those lattices to create fully functional parts.

A critical aspect in any AM process is to be able to characterize the underlying material that is being used. Typically, with metal alloys for example, a high-intensity laser is applied to a powder bed along a CAD-software-guided path, fusing the metal layer-by-layer to build the part. The metal melts locally and, as the heat-source moves on, solidifies with the previous layer to create the fused part. The phase transformations, the cooling rates, and other machine-specific parameters such as print speed guide the metallurgy and the micro-structures that develop.

Such parts can be stronger than those made with traditional manufacturing methods such as casting but the variabilities in mechanical properties can be significant. Hence there is a need to capture the multi-scale and multi-physics nature of the manufacturing process. Here is where the Abaqus user-subroutine framework is already enabling researchers and industry to model the physics of the micro-mechanics behavior while leveraging Abaqus as the global solver for the macro-behavior of the parts.

Aside from material characterization, the 3D-printing manufacturing process itself can introduce significant gaps between the as-designed and the as-manufactured part. In the as-designed part the design is without stresses or distortions and assigned with standard material definitions. However, during AM, which is generally a thermal process today, residual stress build-ups, part distortions, and material variations can arise. Here is where Isight can provide us with a powerful tool to study the effects of manufacturing process parameters such as the deposition path, build orientation, and heat intensity. The tool can then be applied to optimize residual stresses, reduce part distortions, and alter material behavior to meet the in-service conditions of the part—whether those are

static loads, dynamic loads, vibrations, or any of the other engineering issues that you are already solving using Abaqus. Ultimately, what is sought for components operating under in-service loading conditions is the fatigue life of the part. fe-safe®'s deep integration with Abaqus will enable fatigue life evaluation for additively manufactured components as the material data is developed in research.

So to answer our initial questions, yes, simulation has great potential to improve the quality and therefore support the growth of additive manufacturing in every industry, with a breadth of SIMULIA tools that can address many of the issues currently arising as the technology approaches maturity. Now, what is your additive manufacturing story? We would like to hear from you!

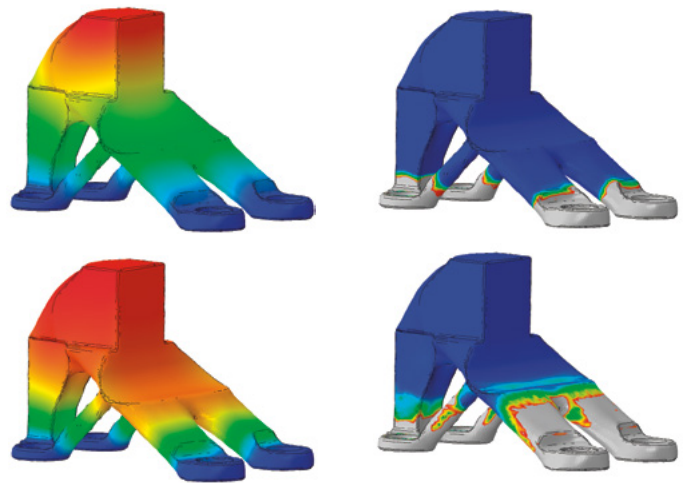

Temperature profile

Stress profile

Manufacturing process parameters affect part production.

**For More Information**  
[www.3ds.com/simulia](http://www.3ds.com/simulia)

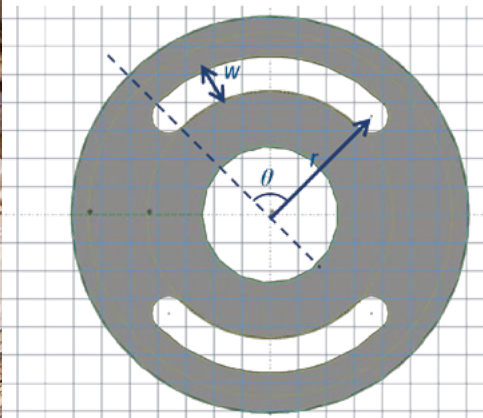

Figure 1. Bushing void parameters used for optimization in Isight.

## ENDURICA: PUSHING THE LIMITS OF BUSHING DESIGN WITH OPTIMIZATION

Automotive suspension systems rely on elastomeric bushings to cushion interfaces between rigid members that otherwise could be damaged by impacts and vibrations. Bushing developers have to find geometry that can deform within the available spatial envelope and hit the compliance target for each axis of loading, as well as provide for durability that lives up to the automaker's warranty.

Given that an experimental program to evaluate bushing performance may cost between USD \$20K to \$200K, screening design options with Abaqus is widely practiced. But did you know that it is now possible to simulate and optimize the durability of a rubber bushing while simultaneously enforcing design constraints on stiffness and geometry?

A recent benchmark was able to hit target stiffnesses in 3 simultaneous directions while optimizing for durability. fe-safe/Rubber™ was used to calculate durability, the Isight parametric optimization solver was used to find an initial bushing geometry satisfying the stiffness targets, and then the nonparametric Tosca optimization solver was used to fine tune the shape of bushing voids.

The Isight solver was used to find the dimensions and placement of a pair of voids described by three independent variables ( $w$ ,  $r$ , and  $\theta$  in Figure 1). The durability of this design was then analyzed in fe-safe/Rubber, where it was found that the life was 9101 loading repeats. Next, the Tosca nonparametric optimization solver was applied with the goal of maximizing the fatigue life by evolving the shape of the

voids. After eight iterations, an optimum life was obtained at 16088 loading repeats. Initial and final iterations of the design are shown in Figure 2 with color contours showing the point of crack initiation on each. For this problem, the iteration process executed in about two hours, and resulted in a life improvement of 76%.

Figure 2. Comparison of initial and final bushing designs showing fe-safe Rubber-computed fatigue life contours and location of crack initiation.

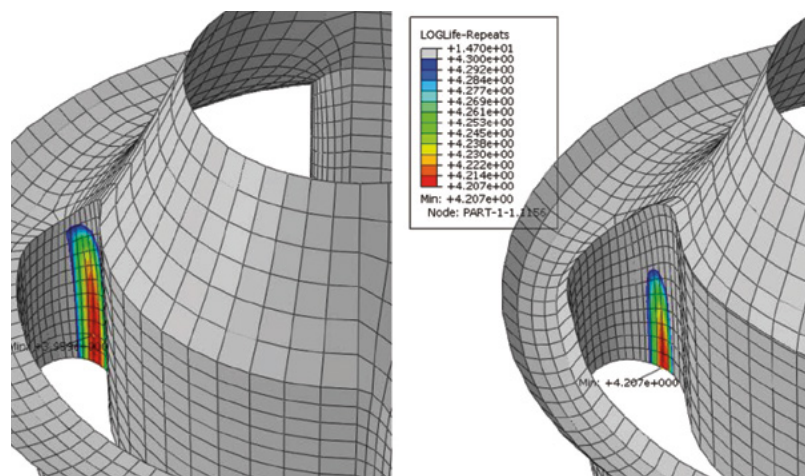

For More Information  
<http://edurica.com>



# MATERIALISE: COMBINING THE MIMICS® INNOVATION SUITE AND ABAQUS FOR PATIENT-SPECIFIC HIP DESIGN

Case presented by Professor Rydholm,  
Skane University Hospital, Lund, Sweden

A Swedish girl was facing a lifetime in a wheelchair because of a congenital disease leaving her with a severely deformed left hip. With the 3D-printed Mobelife aMace® implant and virtual planning in Materialise's Mimics and 3-matic software, she is now pain-free, walking without crutches.

## RECONSTRUCTING THE PELVIS DEFORMATION IN MIMICS®

The 15-year old Swedish girl was suffering from Von Recklinghausen's disease, a congenital disease causing a severe skeletal deformation of the left hip. The neurofibroma destroying her pelvis was surgically removed, but after a femur fracture her situation worsened, forcing her to be home educated for the next two years. Her doctors initially saw very limited or no treatment options and she was looking at a lifetime in a wheelchair.

Professor Rydholm from Skane University Hospital in Lund contacted Materialise subsidiary Mobelife to design a custom acetabular implant. The team of engineers imported and segmented the patient's CT scan in Mimics to reconstruct the defect and analyze the pre-operative situation.

Based on anatomical templates, surgical planning was made directly on the patient's anatomy. This involved placing landmark points and determining the position of the acetabular cup and flanges to secure the cup in the best position, with the surgeon's blessing.

## DESIGNING A PATIENT-SPECIFIC ACETABULAR IMPLANT IN 3-matic®

Using 3-matic, an implant was designed to match the anatomy of the patient's hip. The software facilitated an accurate evaluation of the screw and implant positioning. The patient-specific flanges were designed, the location for the screws was determined and bone quality analyzed. In addition, the team performed finite element analysis in Abaqus to verify whether the implant and bone assembly would withstand the forces and stresses. The final design of the "tri-flange cup" was verified by the surgeon and exported for 3D Printing in titanium.

Almost immediately after surgery, the patient was pain-free and only a few months later, she was out of her wheelchair. Now she is going to school again and this time without crutches!

### For More Information

<http://biomedical.materialise.com/mimics>

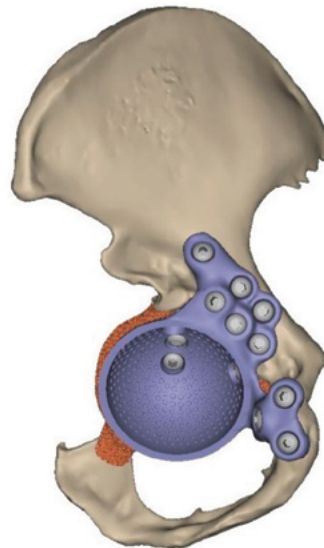

Virtual design of tri-flange patient-specific cup

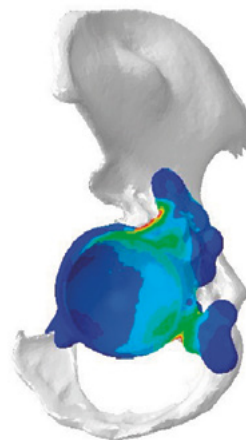

FEA simulation of the tri-flange cup



Custom 3D-printed cup



# SIMULATION HELPS YAMAHA KEEP OFF-ROAD MOTORCYCLES RUNNING COOL

Abaqus helps protect the radiator assembly from tip-over damage

If an off-road motorcycle topples over at low speed during a competition, minor damage can accumulate that affects the motorcycle's performance. For example, the impact from the motorcycle hitting the ground can deform the radiator assembly enough to reduce cooling performance, cause a coolant leak—or both.

Installing a plastic side cover helps protect the radiator assembly, and both the radiator and the plastic cover can withstand deformation if the motorcycle falls on its side at low speed. But Yamaha Motor Co., Ltd.'s engineers found that identifying exactly where to strengthen the radiators and plastic covers in its liquid-cooled, off-road motorcycles was requiring a high degree of trial and error.

"We would have to perform a lot of physical testing to identify the locations for countermeasures, including plastic cover design and thickness, radiator bracket, and bolt locations,"

explains Mr. Masakazu Yamaya, Supervisor, Research & Development Section, Technology Center, Yamaha Motor Co. "This testing to analyze the strength of real-world vehicles would consume a tremendous amount of time and prototype parts. It would also make physical testing expensive and prone to human error."

So Yamaha decided on a different, simulation-based approach, and carefully verified their new analysis methodologies through simplified laboratory testing. "After building various physical test setups to establish baselines for what we needed to know for damage assessment, we developed computer simulations of the physical tests," explains Mr. Yamaya. "We realized that if our simulations correlated well with the results of the physical tests, then the simulations would be an effective design-support tool."



In a Yamaha liquid-cooled off-road motorcycle, the cover protecting the radiator assembly typically hangs off the side of the motorcycle frame. The radiator is a brazed thin-walled aluminum part protected by a plastic side cover. This arrangement provides enough strength for the radiator to withstand damage when the cover strikes the ground at very low speeds; namely, those inevitable—and often embarrassing—times when a motorcycle tips over. Unfortunately, a motorcycle toppling onto a hard surface is rarely righted unscathed; radiator fins and core supports are often bent or broken, and the protective plastic cover is often cracked or shattered to pieces.

“We needed to determine what was important to include in our toppling simulations, including parts, forces, and movements,” says Mr. Yamaya. “We then had to determine what forces related to what results. Finally we had to confirm the accuracy of the simulations against the results of physical tests to determine the strength of the radiator assembly and the plastic cover—individually and mounted together—at various loadings, in order to accurately simulate impacts and impact speeds.”

Using a push jig (Figure 1), Yamaha’s first bench test focused on reproducing the damage to the radiator and plastic cover, and identifying the locations where strength countermeasures were necessary. The test measured the reaction force of the radiator assembly as a proxy for the strength of the radiator and plastic cover. The test was performed with two models of radiator assembly that differed in the design and the thickness of the side cover.

The bench test successfully reproduced the damage to the radiator and the buckling of the plastic cover in a motorcycle that has toppled over. The test also identified dents in the radiator components that were thought to have been caused by surrounding parts. To duplicate the damage situation on the radiator and plastic cover after a tip-over, Yamaha added the bottom radiator part that touches the ground to the assembly.

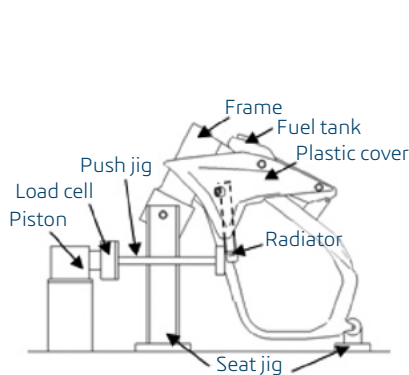

Figure 1. Real-world testing of the radiator assembly employed a push jig and included the frame structure.

## “Simulation for Yamaha is an effective means of identifying locations for strength countermeasures and for developing new and more-effective designs”

—Masakazu Yamaya, Supervisor, Research & Development Section, Technology Center, Yamaha Motor Co.

Another bench test analyzed the strain rate sensitivity in the plastic cover. Tests were run at three pushing speeds between 10 mm/min. and 500 mm/min. The results showed that the maximum load—the buckling load—of the plastic cover is also a function of speed. Moreover, the cover began to buckle when pushed by approximately 20% of the specified stroke in the push jig—regardless of the model of the radiator assembly.

“This meant two things to us,” says Mr. Yamaya. “First, strain rate sensitivity needed to be in the simulations of the plastic cover. Second, the differences in the maximum reaction force in the different radiator models were essentially identical to those when the plastic cover began to buckle. Reproducing the buckling of the plastic cover would indeed accurately determine the maximum reaction force of the radiator assembly.”

For the radiator, the engineers ran two strength tests to determine the necessity of modeling the heat-radiating fins on that structure. One test applied to an ordinary radiator; the other, a radiator without fins. The tests showed the fins accounted for approximately 50% of the reaction force generated by the radiator. Although the thickness of each fin is only about 0.1 mm, the large number of fins together account for the greater effect on the radiator reaction force. Based on these results, Yamaha decided to include the fins in its strength simulation.

“All of these physical tests confirmed what components we needed to model in the digitized strength simulations,” explains Mr. Yamaya. “The tests also provided baseline results for comparing the simulation model against the physical models.”



Figure 2. Two views of analysis results of an integrated radiator assembly model.

# Case Study

## DEVELOPING STRENGTH SIMULATIONS OF COMPONENTS

As Yamaha began creating their virtual models, they decided to run their simulations as quasi-static problems involving the dynamic explicit analysis methods found in Abaqus FEA from Dassault Systèmes' 3DEXPERIENCE technology, SIMULIA. The explicit method was chosen because it is less computationally intensive than full implicit-type analyses when dynamically analyzing static problems. First the team developed separate cover and radiator models; then they combined them into full assembly models.

For the plastic cover, the simulation model was created using shell elements, the fuel tank was expressed as a rigid body, and the fuel tank reference node was fixed. Locations fastened by bolts were expressed by multipoint constraints, and constraints around the bolt center axis were free. The plastic cover and the fuel tank could interact with each other by contact definition. Multiple mounting points were constrained in the FEA model to forcibly vary the position of the reference node. Strain-rate sensitivity for the plastic material in the radiator cover was included using the test data for three different strain rates including the assumption of perfect plasticity at the highest strain rate.

The maximum load in the simulations was approximately 10% higher than that from the physical tests. "We determined this difference was because of the higher rigidity in the model of the plastic part where the thickness of the part's geometry changes gradually," says Mr. Yamaya. However, the buckling seen in the plastic cover simulations matched well with the physical tests.

Shell elements were used to model all the radiator parts except its heat-radiating fins. The fins were expressed using multipoint constraints because creating the actual shapes of the fins and fitting them into the model of the radiator would have taken too much time and added unnecessary complexity to the simulation.

"We created the fins in Abaqus as a user material for honeycombs, based on real-world calibration of a fin unit model," explains Mr. Yamaya. "The simulation used a dynamic stress-strain relation that had the equivalent mechanical behavior as the fins. As a result, we were able to easily create the simulated fins with solid elements, and they more than adequately reproduced the response of the actual fin unit."

In the simulations, the generated load was approximately 20% higher in the radiator model than in the physical push jig test. Mr. Yamaya believes that the rigidity of the simulated radiator fins is higher than the actual fins because the model omits the slits machined onto the surface of the actual fins.

## VERIFYING THE RADIATOR ASSEMBLY SIMULATIONS

Finally, an integrated radiator assembly model was created to reproduce the correct interaction behavior between components, including the radiator and plastic cover (Figure 2).

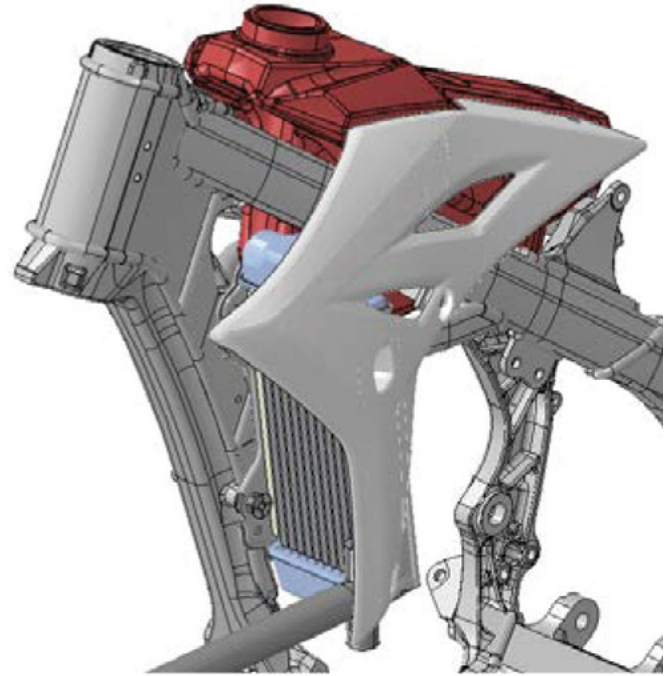

Figure 3. Final design of a radiator assembly with plastic cover that more effectively incorporates strength countermeasures against damage from motorcycle tip-overs.

Yamaha could then determine the total amount of internal energy and kinetic energy for the radiator, plastic cover, and full assembly of both components. "The percentage of total kinetic energy relative to total internal energy is on the order of several percent," says Mr. Yamaya. "This shows that a valid solution can be provided by addressing radiator assembly deformation as a quasi-static problem."

In fact, he continues, "for the radiator, the same damage conditions of overall twisting were reproduced with nearly exact correlations between the physical test and simulation results. The buckled part of the plastic cover correlated perfectly as well, so we were confident to try out different designs for the radiator's plastic cover."

Based on these findings, Yamaha is now confident that its radiator assembly strength simulations can accurately predict physical test results. Using simulation, says Mr. Yamaya, "provides us with a detailed analysis of the behavior of the radiator and plastic cover during physical test—behaviors that would otherwise be difficult to observe from testing alone. Simulation for Yamaha is an effective means of identifying locations for strength countermeasures and for developing new and more-effective designs" (Figure 3).

Image reference: All figures, except Fig. 1, are from "Development of Strength Analysis Method for Off-Road Motorcycle Radiator Assembly -- 19th Small Engine Technology Conference.

**For More Information**  
<http://global.yamaha-motor.com>



# Teachers at Dassault Systèmes

## PROPELLING AHEAD!

The TADS (Teachers at Dassault Systèmes) program, established in 2013, is part of a corporate engagement commitment to promote Science, Technology, Engineering, and Math (STEM) education. The three main goals of the program are to Educate Teachers by providing first-hand knowledge about STEM careers, to Educate Students by enabling teachers to create learning modules for the classroom, and to Educate Communities by increasing awareness of Dassault Systèmes within the local public school communities. During a 6-week internship at SIMULIA, TADS teachers create curriculum modules that can be used in their classrooms and shared with other teachers.

David Duke, SIMULIA R&D QA Manager, is working with the 2015 TADS teachers, Donn Chu and Marta Hidalgo, of the newly formed Cisco Academy at Mount Pleasant High School, in Providence, Rhode Island. The academy aims to provide students with opportunities to learn about, play with, and experience computer and network technologies.

### What is your position/school/class/department?

**DONN:** I teach Computer Information System (CIS), Cisco Networking, and Web Design at Mount Pleasant High School. My responsibilities include managing the school's technology equipment, training, and assisting teachers in technology integration.

**MARTA:** I teach Computer Science, Pre-engineering, and ELL at Mount Pleasant High School.

### Tell us a little about yourself.

**DONN:** I have been teaching for 17 years in Providence schools. I graduated from Rhode Island College with a degree in Secondary Education, and received my M.A.T in Educational Technology from National University.

As a teacher, my actions can help influence a child to make informed and responsible choices in their life. Teaching allows me to continue my own journey as a student and a lifelong learner.

**MARTA:** I moved to Providence from the Dominican Republic when I was 12 and attended Hope High School. After only 4 years of ESL courses, I attended Johnson & Wales University and received a degree in Computer/Business Applications, Information Science and a M.A.T. in Business Education.

### Why were you interested in becoming a TADS teacher?

**MARTA:** I wanted to offer the ELL (English Language Learners) students an opportunity to take STEM courses while learning English. 30% of our students at Mount Pleasant High School are ELL.

### How did you choose the project, Propelling Ahead?

**DONN AND MARTA:** The 3-4 week long CTE/STEM instructional unit, Propelling Ahead, was designed to allow students to explore engineering concepts. The students work



(Left to right) Donn Chu, Marta Hidalgo, and David Duke.

**"Instructional simulations engage students in 'deep learning' that empowers understanding as opposed to 'surface learning' that requires only memorization. Simulation works!"**

—Donn Chu

collaboratively in teams to design and build a propeller-powered boat. They test their boats, redesign as required, and then race their boats against the other teams. The project will help us prepare our pre-engineering students for The Academy's Robotics on the Water (AROW) event competition (<https://providenceschools.wordpress.com/2015/03/19/participation-in-coast-guard-academy-robotics-on-the-water-competition-arow-more-than-doubles-in-its-2nd-year/>). Our students won second place in the competition this past year, and we hope that the new curriculum will help them win first place next year.

### What were you trying to understand from this project?

**DONN AND MARTA:** The project focuses on engineering, problem-solving, and critical thinking skills. The goal is to get students to conduct research, learn to use SOLIDWORKS, understand the Engineering Design Process (EDP,) and apply it to produce a viable solution to an engineering problem.

### What do you hope is the biggest take-away for the students?

**DONN:** Hopefully students will see that engineering can be thrilling and consider a STEM career.

**MARTA:** I am hoping to inspire some of our ELL students to pursue STEM careers. It will have a tremendous impact on their lives, whether they stay in Providence or choose another place in the world.

### What would you say the value of simulation is?

**DONN:** The value of using simulation in the classroom is best summed up by the Chinese proverb, "Tell me, I forget. Show me, I remember. Involve me, I understand." Instructional simulations engage students in "deep learning" that empowers understanding as opposed to "surface learning" that requires only memorization. Simulation works!



## NOW HEAR THIS!

### SIMULIA tools help improve product design and reduce development time for hearing-aid producer GN ReSound

Danish manufacturer GN Store Nord A/S is a global leader in sound processing. Producer of the popular Jabra line of wireless headsets, the company enjoys a rich history of technological advancements, beginning with its work in the telegraph industry in 1869. What was once the Great Northern Telegraph Company has since diversified, and today markets a deep portfolio of audio products across several subsidiary companies.

One of these is the GN ReSound Group, which designs and manufactures a broad line of hearing aids and accessories. Its mission is straightforward: to continuously develop solutions to help people rediscover hearing, so they can live rich, active and fulfilling lives.

That mission is on target: According to the World Health Organization, more than five percent of the world's population suffers debilitating hearing loss, measured as a reduction in sensitivity to sound of 40 decibels (dB) or greater. That's 360 million people

unable to participate in a quiet conversation, or enjoy the gentle sounds of a rainy night. Nearly one-tenth of them are children.

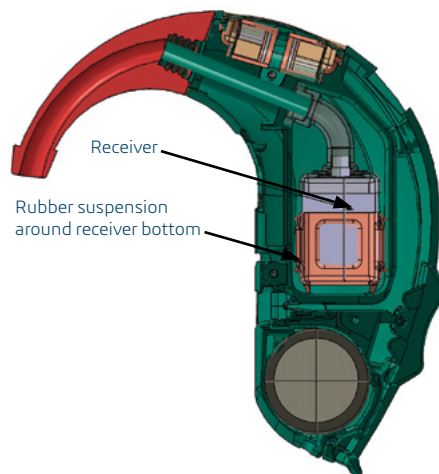

Figure 1. Anatomy of a hearing aid.

Of course there are far more people than that with some level of “normal” hearing loss, the most common cause being age—roughly half of all adults 75 years and older experience difficulty hearing—although head trauma, chronic ear infections, certain medications, tinnitus (ringing in the ears), and workplace wear and tear may all lead to loss of hearing. The good news is that most of these problems are easily solved through the use of a hearing aid.

GN ReSound brings high-tech to hearing aids. The days of bulky boxes and not-so-discreet cords have been replaced by sleek digital devices that fit in the ear or directly behind it, eliminating the stigma associated with Grandpa's clumsy analog trumpet. So too has sound quality improved, with noise-processing software that



tunes out background clutter while providing a more natural and focused listening experience. GN ReSound even has an app for that, allowing the connection of Bluetooth-enabled smart phones and accessories to its line of 2.4 GHz wireless hearing aids. Simply put, GN ReSound helps people hear better.

### SIMULATING A RIGHT FIT

Designing smaller, smarter hearing-aid devices is no easy task. It requires advanced product engineering and manufacturing techniques to fit sophisticated electronics into a package no larger than a fingernail. And even the best of designs can go awry once worn outside controlled laboratory conditions, where hearing aids are susceptible to environmental conditions such as heat and moisture, vibration, and impact damage. Testing against these failure modes is just one of the reasons why GN ReSound turned to Abaqus Unified FEA from SIMULIA, the Dassault Systèmes brand for realistic simulation.

As Morten Birkmose Søndergaard, Senior Acoustic Engineer at GN ReSound’s Research and Development facility in Ballerup, Denmark, explains, “These days the development of hearing aids demands shorter time to market and higher rate of success in achieving all the requirements of each device. So it’s very important to be able to reliably predict performance and improve designs early on in the process.”

The GN ReSound team began using Abaqus in the R&D lab over 14 years ago. Simulation has since become a permanent task in the project plan for any new product rollout. “Without simulation,” Søndergaard says, “it would be impossible for me and the team to do our jobs.”

“Before Abaqus, we would have to use a trial and error approach to product testing. Now simulation helps us understand potential problems much more quickly, and improve the quality and robustness of our designs. We also have the opportunity to front-load a project with simulations to gain as much knowledge we can early on, giving us the best possible starting point.”

### JUST DROP IT—VIRTUALLY

One of these projects involved simulating a free fall of a BTE (Behind The Ear) instrument against a hard surface.

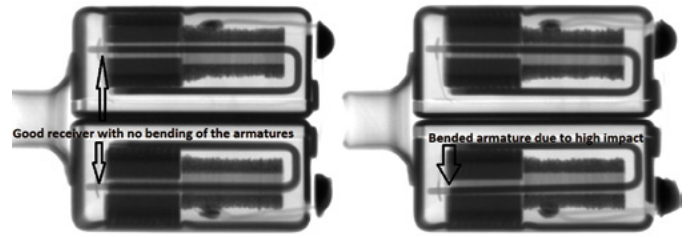

Image 2. X-ray of hearing aid receivers showing intact (left) and bent (right) armatures.

The delicate mechanism responsible for high-quality sound reproduction—the receiver—is prone to damage when the hearing-aid device is dropped, a fairly common occurrence when swapping out batteries (see Figure 2). Søndergaard says understanding the results of accidents such as this is increasingly important as products become smaller, leaving less room for error when designing internal components.

The team split the test into two simulations. The first involved modeling of the rubber suspension that houses the receiver, isolating it from vibration and preventing feedback. This is also the primary protection against a fall. STEP files of the hearing-aid assembly were imported into Abaqus/CAE. Material attributes and mesh values were then assigned to the various components—in the case of the rubber suspension, mechanical stress-strain parameters were used together with the material’s dynamic shear modulus. A “shrink fit” function was then applied to the suspension using Abaqus/Standard, virtually stretching the rubber over the receiver’s rigid body to assess the rubber’s viscoelastic behavior when placed in its intended position (see Figure 3).

The second simulation modeled the final two milliseconds of the BTE’s free fall to planet Earth. By applying a velocity condition to the hearing aid model in Abaqus/Explicit, the engineers were able to calculate the g-force experienced by the receiver on impact, which beyond a certain level bends the tiny armature within, destroying its transmission capabilities. Engineers had previously determined the maximum allowable g-force at 14,000 g’s, yet Abaqus quickly predicted that up to 15,000 g’s of peak force was possible when striking at that velocity, well above the receiver’s limit.

Image 3. Pre-deforming of rubber suspension. The deformed suspension is shown to the left and the undeformed to the right

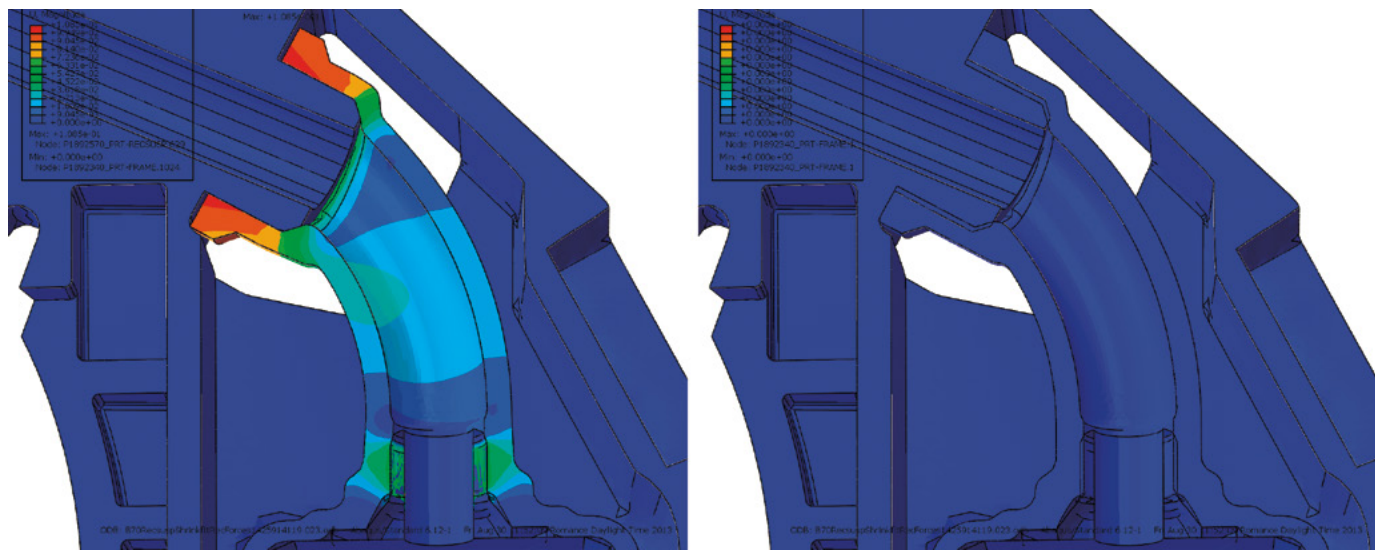

# Case Study



Image 4. High-speed video is used to record impact. Left photo is 0.9 after impact, middle is 0.1 after impact, right is at impact. Note motion of receiver at center of device.

Since there's no way to measure actual g-force inside such a small device, simulation results were correlated using high-speed video of the impact (see Figure 4). A number of impact tests were also conducted, repeatedly striking each side of the device using a pendulum to mimic drop force. In each instance, physical damage correlated to the simulated g-forces within Abaqus, thus validating the models.

## LISTENING TO THE DATA

Product engineers were then able to use this data to redesign the area surrounding the receiver. "Even during the first simulation, we could see how the internal parts were moving around during the impact," Søndergaard says. "Abaqus increased our understanding of the problems, and gave me and the team new ideas of how to solve them." To further constrain the movement of the suspension and its precious cargo at the time of impact, several iterations of small rubber tabs were added, eventually giving the engineers a product that consistently reduced force to 11,000 g's.

There's more to receiver testing than watching for bent armatures. Vibro-acoustic tests are also required, since even a slight amount of deviation here may cause harmonic distortion, or even a feedback loop between the receiver and nearby microphones. Here, GN ReSound used SIMULIA's Tosca suite for structural optimization of rubber components, identifying the ideal topology that delivered the best vibro-acoustic stability.

Based on their recent successes, the team looks forward to expanding its simulation efforts with SIMULIA tools. "We have also tried Isight for process automation and design exploration, and I believe we will use both it and Tosca more and more in the future along with Abaqus," says Søndergaard. Future plans for simulation also include changing more of the rigid components in the BTE model into elastic-plastic ones, to better simulate behavior on impact, as well as further refine the material properties of models.

**"Ultimately, it's about developing the very best products possible for our customers. SIMULIA's tools help us do just that."**

—Morten Birkmose Søndergaard,  
Senior Acoustic Engineer, GN ReSound

Future investigation is also planned to query several assumptions made in the initial tests, including the use of a fixed "tie" between the suspension and receiver that bypasses unknowns in the friction coefficient between the two materials. Also, the "hit" on the test device was made at the exact same point and direction in each simulation, eliminating variance that may be a factor in real-world conditions and should be included in later analyses.

"Simulation has proven to us that it's quite capable of handling the complexity of our hearing aids, and I'm confident we can work with even bigger models without any issues," Søndergaard says. "Tools such as Abaqus and Tosca have definitely helped us to be more innovative. They increase the speed at which we can build new models more precisely and increase our understanding and knowledge of the challenges."

"The faster you can make a good model, the more it benefits the project overall. This is important, because the acoustic technology we're developing today will be used in hearing aids a year or two from now. Ultimately, it's about developing the very best products possible for our customers. SIMULIA's tools help us do just that."

## For More Information

[www.gn.com/About-GN/GN-ReSound](http://www.gn.com/About-GN/GN-ReSound)



# SIMULIA Spotlight: Frans Peeters

When Frans Peeters, SIMULIA's vice president for Europe, announced his retirement during his 2015 SCC keynote speech this spring in Berlin, he received a lengthy standing ovation. It was well-deserved after 21 years with a company that grew from Hibbitt, Karlsson & Sorensen (HKS) to ABAQUS to SIMULIA as part of the Dassault Systèmes family.

After Frans' presentation, he sat down with us to discuss the highlights of his career and his plans for the future.

## SCN: Why did you join HKS?

**PEETERS:** Over the years I started appreciating the value of quality. I first worked with David Hibbitt at another company, and when I later joined him at HKS it felt like coming home. I saw how this company and these people were devoted to providing complete solutions to the market, in the sense that people could take advantage of the technology but also could rely on the quality of the products and methods around it. In that sense I was inspired by David and the rest of team, to see how they positioned themselves in the market early on.

## SCN: How have you seen SIMULIA technology evolve over the years?

**PEETERS:** Originally the technology was used to get some insight in a qualitative manner, but of course it was sometimes not very good prediction in the early days due to the size and limits of the hardware and the technology itself. But around the 1990s there were new developments of specific workflows responding to the needs of particular industries. We tried to provide complete, in-depth solutions and they were well-received by our customers.

About ten years ago we moved to assembly analysis. For me the eye-opener at the time was that for very complicated structures, like cars or even airplanes, we could do the most advanced nonlinear analysis in a very predictive manner. In contrast to what we saw 20 years ago you finally have reached the point where this technology can be used to predict real behavior. This is important, as there are cases where you cannot do physical testing and have to rely on virtual tests.

## SCN: Tell us a bit about the value of the SCC.

**PEETERS:** As our software advanced, very soon there was the perception that meeting with users to share knowledge was a very important aspect of deploying this technology. HKS started the first Abaqus Users Conference in Oxford, England in 1988. After joining the company in 1994 I've attended every one of the worldwide conferences we hold, alternating between Europe and the U.S. I even organized several of them myself in the early days, arranging the hotels and doing all the behind-the-scenes work!

Now the SCC is a very large, professional, successful event. But we still follow the core format of the early days, updating our users on new functionality and then having them share how



they've benefitted from our technology and accomplished major things.

## SCN: So what's next in your life?

**PEETERS:** I've been kind of a workaholic, so I'm looking forward to more personal travel with my wife. I'm also lucky to have some very nice grandchildren now, and it's really fun to spend time with them and watch them grow up.

## SCN: Would you recommend that your grandchildren become engineers?

**PEETERS:** Well, both my kids are engineers and yet, as my wife says as a joke, "I have three engineers in the family and I still have to repair the bikes myself!" But of course there's nothing wrong with engineering!

I've been very privileged to be in this field and to serve the industry and the individuals who've kept me going. I'm pleased to have interacted with so many interesting people and have been able to contribute to advancements in the technology.

Frans Peeters (Back row, center)



## MODELING TIRE BURST IN THE SMALL OVERLAP FRONTAL CRASH SIMULATIONS

In small overlap frontal impact, the vehicle's outer edges, which aren't well protected by the crush-zone structures, are forming the main load-carrying path. Tires and wheels as well as the suspension system are usually subjected to the impact force. The tires hit by the rigid barrier usually burst with the rupture of tire and wheel as well as lose their air seals by de-beading. The tire burst affects the kinematics and deformation of the vehicle's suspension and consequently affects the vehicle's crash performance.

Accounting for the pressure decrease due to tire burst is important for accurate prediction of the vehicle's crash response. Therefore modeling the tire burst which is caused by material damage and/or de-beading due to loss of seal between tire and rim is key to replicate the small overlap crash event. This article presents the finite element modeling of tires in Abaqus to account for tire burst in crash simulations.

### TIRE MODELING

The first step is to create a two-dimensional axisymmetric tire inflation model. This includes the modeling of tire tread and side wall using axisymmetric solid elements; the modeling of tire belts and carcass with embedded axisymmetric surface elements; and the wheel with axisymmetric shell elements.

The second step is to generate a symmetric three-dimensional tire model by revolving the two-dimensional model at the end of the inflation analysis by 360 degrees. With the "FILE NAME" parameter of the \*SYMMETRIC MODEL GENERATION option in Abaqus/Standard, a three dimensional model with the extension name .axi will be created. This file includes the node, element and section definitions.

### MODELING TIRE BURST

The key feature to replicate the tire burst is to model the two failure mechanisms: material ruptures in tire and wheel rim and de-beading. Therefore, the following modifications must be made to the three-dimensional tire model: The tire side wall and the wheel rim must be modeled as two separate parts to allow separation in order to account for the de-beading. The steel bead needs to be modeled so that there is enough resistance and friction to keep the tire intact when inflated with suggested tire pressure. Here, we model the tire bead using 3D beam elements. Material properties of the tire tread and side wall must be able to capture the destructive damage of the rubber material upon impact thus creating openings on the tire allowing air to escape outside the tire and burst. Depending on the conditions, such as impact angle and impact speed, either mechanism may trigger the tire burst. Whichever of the two mechanisms—material rupture and de-beading happens first—will be followed by tire burst and rapid drop in the tire pressure and loss of support to the vehicle's suspension system.

The Abaqus fluid cavity feature is used to model the internal pressure of the tire. A closed volume is defined by using surface elements that cover the inside of the tire and rim by sharing nodes with the internal layer of nodes of the tire and rim. The pressure of the tire is related to the closed volume. To account for the material failure, we use the hyperelastic material together with damage criteria for the rubber material properties of the tread and side wall. Upon material damage and element removal, the surface elements underlying the rubber material will be free to be pushed outside of the tire by pressure difference. The fluid cavity volume increase quickly and the tire pressure drops as the volume increases. To account for the de-beading, the area that the tire is contacting with the rim (red area shown in Figure 2) needs to be modeled as follows: The ring of surface elements on the rim, where one is attached to the tire side wall, are re-meshed with a finer mesh, thus creating two layers of free nodes on the closed

Figure 1. Tire Modeling.

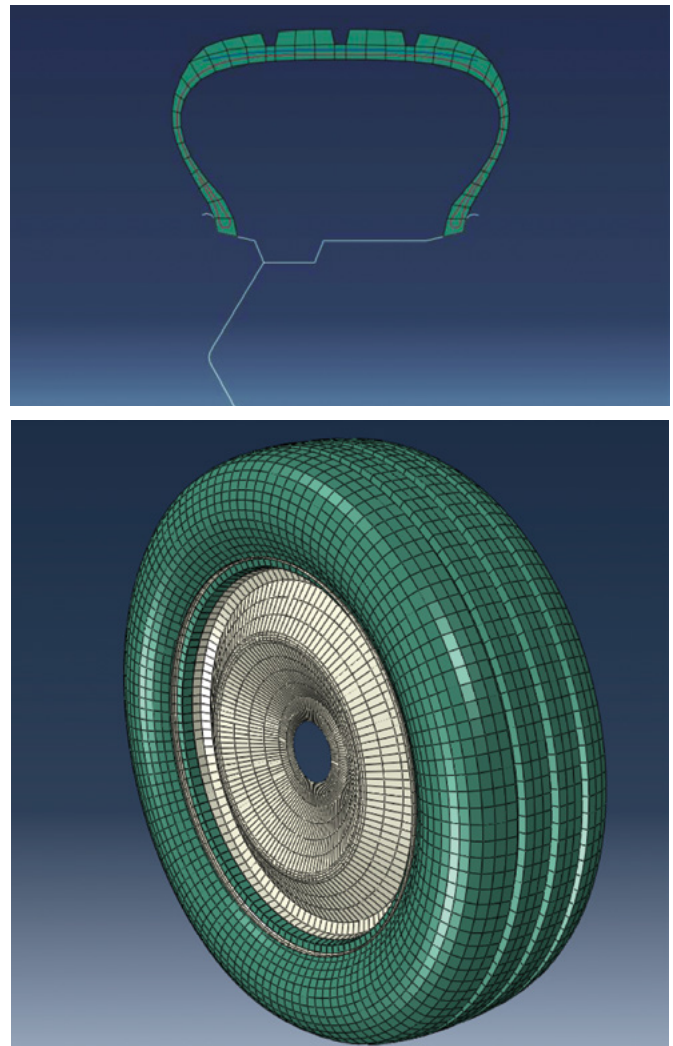



volume of the fluid cavity. Two rings of shell elements with negligible material stiffness are added, sharing nodes with the two rings of surface elements. Contact is defined between the two rings of shell elements and the rim in order to keep the free nodes in place when tire and rim are not separated. The free nodes are offset to avoid being in the same location as the rim for better contact conditions. When de-beading happens, the free nodes will be free to go through the opening thus making the volume larger and depressurizing the tire. The modeling schematic is shown in figure 2. The red lines correspond to the surface elements with underlying shell elements that close the gap between the tire and the rim, thus making a closed volume for the fluid cavity.

### SIMULATION RESULTS

Vertical impact, lateral impact and a 45-degree impact were simulated. It was found that in the vertical impact, when the impactor contacts the tire on the tire tread, the rubber material damages where the rim also contacts the tire tread. The tire burst follows with rapid pressure drop. In the lateral impact when the impactor contacts the tire side wall, the side wall separates from the rim. The tire burst follows with rapid pressure drop. In the 45-degree impact, both material damage and de-beading happens, resulting in tire depressurization.

Figure 2. Modeling Tire Burst.

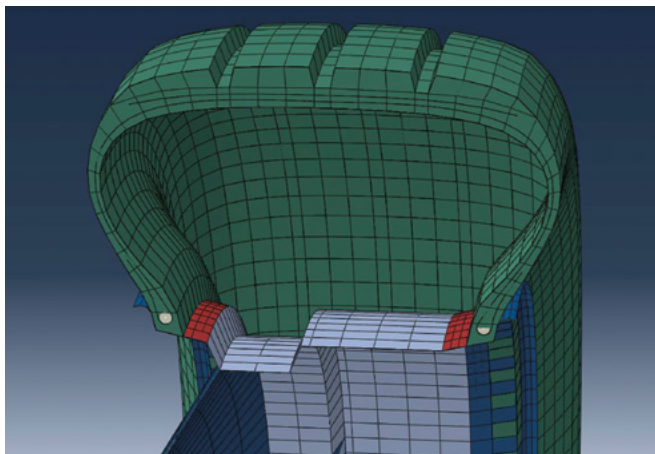
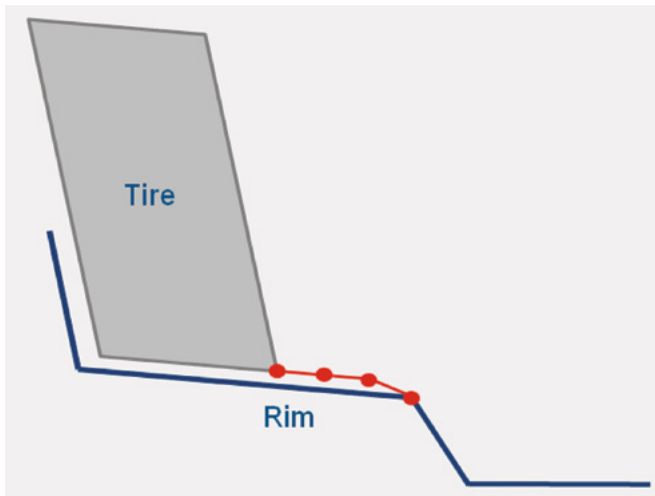
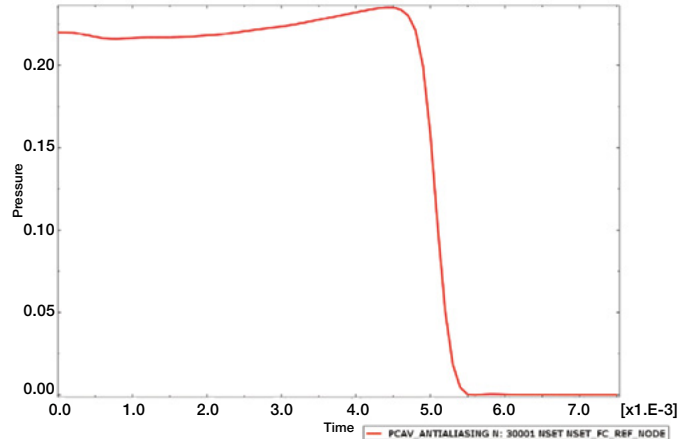
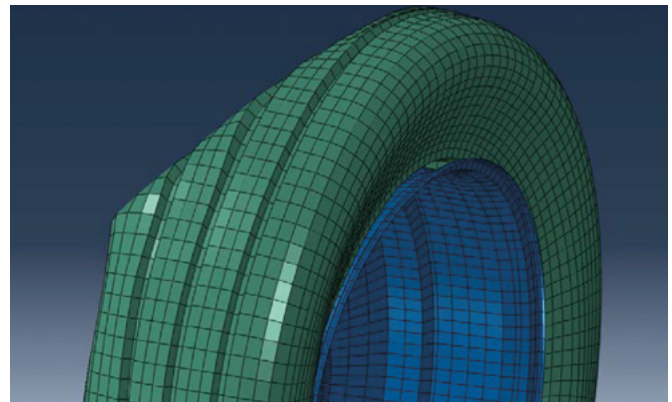
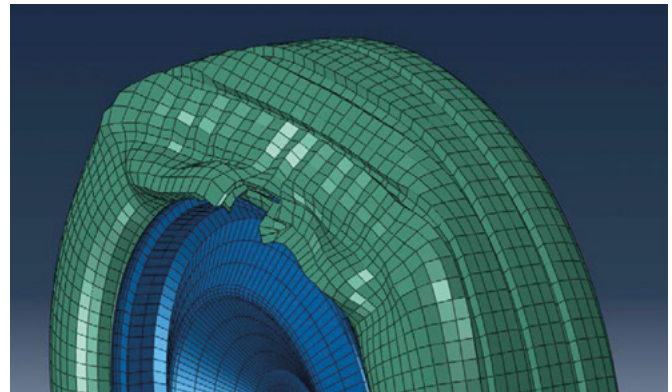

Figure 3. Simulation Results.



In figure 3, we show the simulation result of the 45-degree impact. Material failure happened first at about 4 msec and de-beading follows at about 4.5 msec at the other side of the tire where the rim moves faster than the tire wall due to impact. The fluid cavity pressure curve is obtained from the simulation. It is shown that the pressure keeps increasing after material damage due to air escaping speed is still lower than the pressure increase due to impact. But after 0.5 msec the pressure starts to drop. The tire entirely deflates at about 5.5 msec. The bursting process takes a total of 1.5 msec from first appearance of material failure to zero pressure.

**For More Information**  
[www.3ds.com/simulia](http://www.3ds.com/simulia)

# Let Training from SIMULIA Experts Help You!



SIMULIA Centers for Simulation Excellence provide regularly scheduled training courses at our offices. An extensive range of courses are available from basic introductions (Introduction to Isight) to advanced courses (Abaqus/Explicit – Advanced Topics) that cover specific analysis topics and applications.

Some courses may be followed by a one-day hands-on workshop. Online-only training classes are also available. We also offer on-site courses, which can be customized to focus on topics of particular interest to your organization. Contact your local SIMULIA Center for Simulation Excellence for details.

**For more information, visit [www.3ds.com/simulia-training](http://www.3ds.com/simulia-training)**